

COASTLINE FIRE TABLE - 60" x 24"

Powder Coat

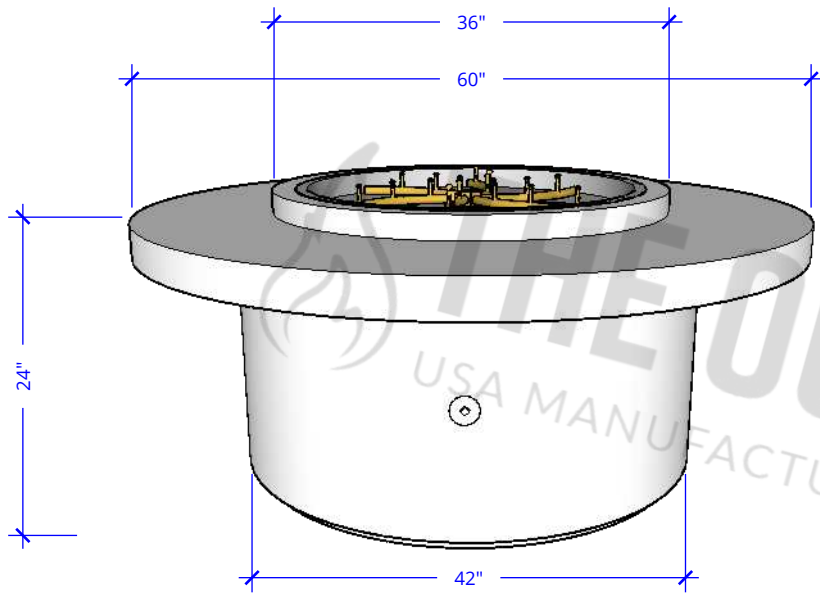

ISOMETRIC VIEW

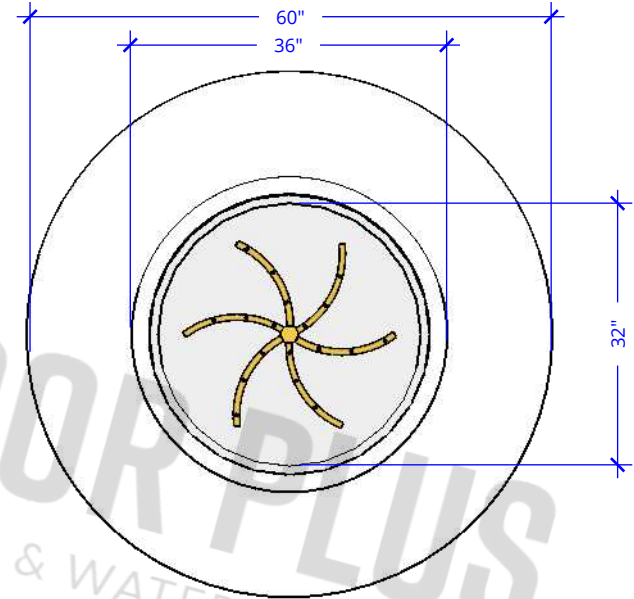

TOP VIEW

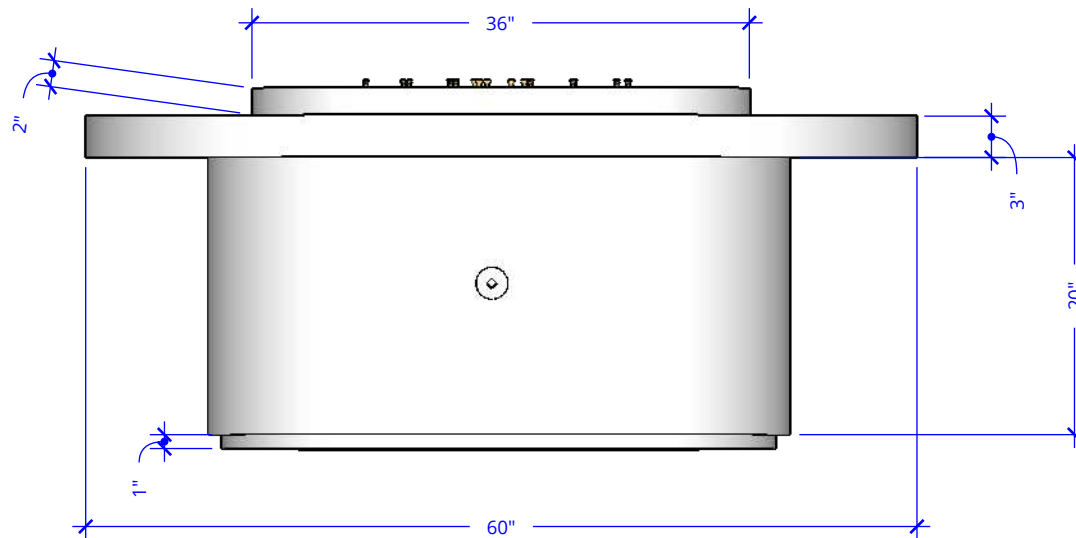

FRONT VIEW

60" x 24" Coastline Fire Table - Powder Coat Metal	
SKU	OPT-CSTLNPC6024(XXXX)
Material	Powder Coat
Finish	TBD
Gas Type	Natural Gas/Liquid Propane
BTUs	65,000
Sugg. Fire Glass	76 Lbs