

Parallel 202 Prefilter Kit

High-volume prefilter system maximizes life of submicron filters



APPLICATIONS

Add-on components address high particulate, algae and other related water issues

High volume combination applications
Extends the life of submicron filters

FEATURES AND BENEFITS

Delivers quality water to high volume fountain dispensers, coffee makers and ice machines where extreme water conditions demand larger capacity filters.

Ideal for water supplies with excessive dirt loads.

Special dual gradient prefilter cartridges reduce dirt and other particles at least 10 microns in size.

Parallel 4" x 20" sumps hold high efficiency cartridges.

Extends the life of submicron filter system cartridges.

Built-in water meter determines water demand and usage for all equipment.

Additional draw down capacity for high volume locations and peak demand times.

Allows for 12-gallon reserve of filtered water.

Includes fittings for connections to existing Everpure filtration systems.

OPERATIONAL TIPS

Change cartridges on a regular 6 month preventative maintenance program.

Change cartridges when capacity is reached or when pressure falls below 10 psi.

Service flow rate must not exceed 10 gpm.

Always flush the filter cartridge at time of installation and cartridge change.

Everpure water treatment systems (excluding replaceable elements) are covered by a limited warranty against defects in material and workmanship for a period of five years after date of purchase. Everpure replaceable elements (filter cartridges and water treatment cartridges) are covered by a limited warranty against defects in material and workmanship for a period of one year after date of purchase. See printed warranty for details. Everpure will provide a copy of the warranty upon request.



Parallel 202 Prefilter Kit: EV9336-52
EC204 Replacement Cartridge: EV9108-40
Parallel 202 Without Surge Tank: EV9100-24
Extra Capacity Surge Tank: EV9336-51

SPECIFICATIONS

Overall Dimensions:	26.125" H x 23.25" W x 8.5" D (66.3 x 59 x 21.5 cm)
Inlet Connection:	3/4"
Outlet Connection:	3/4"
Service Flow Rate:	Maximum 10 gpm (37.8 Lpm)
Pressure Requirements:	10 – 90 psi (0.7 – 6.2 bar), non-shock
Temperature:	35 – 100°F (2 – 38°C)
Electrical Connection:	None
Shipping Weight:	Prefilter 32.5 lbs. (14.7 kg); Surge Tank 35 lbs. (15.8 kg)
Operating Weight:	Prefilter 41.5 lbs. (18.5 kg); Surge Tank 133 lbs. (60.3 kg)

Parallel 202 Prefilter Kit

EV9336-52

INSTALLATION TIPS

Never use saddle valve for connection.

Use 3/4" water line.

Do not connect system to water-cooled condenser.

Install vertically with bowls hanging down.

Allow 2-1/2" clearance below the cartridge for easy cartridge replacement.

Flush cartridges by running water through system for five minutes at full flow.

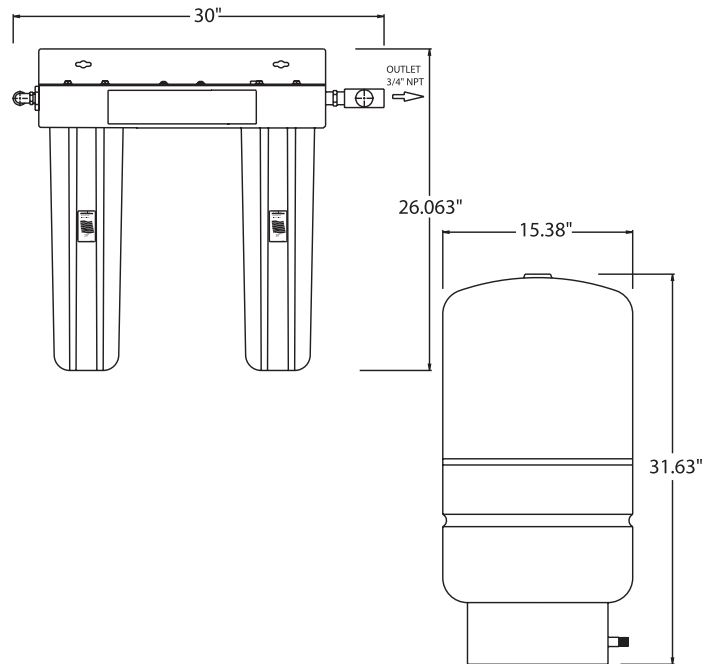

The contaminants or other substances removed or reduced by this drinking water system are not necessarily in your water. Do not use with water that is microbiologically unsafe or of unknown quality without adequate disinfection before or after the system. Systems certified for cyst reduction may be used with disinfected water that may contain filterable cysts.

EVERPURE reserves the right to update specifications, change prices, or make substitutions without notice.

EVERPURE®

WATER YOU CAN TRUST®

Visit our website at www.everpure.com

Everpure-SHURflo India
Green Boulevard, B-9/A, 7th Floor -
Tower B Sector 62, Noida - 201301
TEL: 91.120.419.9444
FAX: 91.120.419.9400
EMAIL: indiacustomer@Pentair.com

Everpure-SHURflo Japan Inc.
Hashimoto MB Bldg. 7F
3-25-1 Hashimoto, Midori-ku
Sagamihara-Shi Kanagawa 252-0143
JAPAN
TEL: 81.(0)42.775.3011
FAX: 81.(0)42.775.3015
EMAIL: info@everpure.co.jp

Everpure-SHURflo China
21F Cloud 9 Plaza, No 1118
Shanghai, 200052
CHINA
TEL: 86.21.3211.4588
FAX: 86.21.3211.4580
EMAIL: China.Water@Pentair.com

Pentair Filtration Solutions, LLC
World Headquarters-Everpure/SHURflo
North and South America Sales
1040 Muirfield Dr.
Hanover Park, Illinois 60133
USA
TEL: 800.942.1153 (US only)
TEL: 630.307.3000
FAX: 630.307.3030
EMAIL: cseverpure@pentair.com

Everpure-SHURflo Australia
2 Redwood Drive
Notting Hill
Victoria, 3168
AUSTRALIA
TEL: 011.61.39.574.4000
FAX: 011.61.39.562.7237
EMAIL: au.everpure@pentair.com

Everpure-SHURflo Southeast Asia
18 Boon Lay Way
#04-110/111
TradeHub 21, 609966
SINGAPORE
TEL: 65.6795.2213
FAX: 65.6795.2219
EMAIL: cseverpure@pentair.com

Everpure-SHURflo Europe
Pentair Water Belgium bvba
Industriepark Wolfstee
Toekomstlaan 30 B-2200 Herentals
BELGIUM
TEL: +32.(0).14.283.500
FAX: +32.(0).14.283.505
EMAIL: sales@everpure-europe.com

EV9336-52 MR11