

Installation Instructions



All-Fuel Chimney System
5" to 8" diameter

DURATECH[®]

DuraVent.

A MAJOR CAUSE OF VENT RELATED FIRES IS FAILURE TO MAINTAIN REQUIRED CLEARANCES TO COMBUSTIBLE MATERIALS. IT IS OF THE UTMOST IMPORTANCE THAT DOUBLE WALL DURATECH BE INSTALLED ONLY IN ACCORDANCE WITH THESE INSTRUCTIONS.

NOTE:

Read through all of these instructions before beginning your installation. Failure to install as described in this instruction will void the manufacturer's warranty, and may have an effect on your homeowner's insurance and UL listing status. Keep these instructions for future reference. This booklet also contains instructions for installing a venting system within an existing masonry chimney, and for installations passing through a cathedral ceiling.

Dear Customer, Installer, or End User:

We welcome any comments, ideas, input or complaints regarding matters pertaining to our DuraVent products.

If you are searching for tech support or product information, please call us at 800-835-4429.

Or email us at:

techsupport@duravent.com



LISTED
MH7399

ALL-FUEL CHIMNEY SYSTEM, 5" TO 8" DIAMETER

For the most up-to-date installation instructions, see www.duravent.com

CONTENTS

CLEARANCES 4

NON-COMBUSTIBLE INSULATION 4

PERMITS 4

DURATECH CHIMNEY APPLICATIONS 4

INSTALLATION NOTES 5

CHIMNEY HEIGHT 5

CHIMNEY ENCLOSURE REQUIREMENTS 5

SUPPORT REQUIREMENTS 6

METHOD #1: CEILING SUPPORTED 7

OFFSET ELBOW INSTALLATION 12

EXTENDED ROOF BRACKET INSTALLATION 13

METHOD #2: ROOF SUPPORTED INSTALL 15

METHOD #3: TEE-SUPPORTED INSTALL 17

METHOD #4: MASONRY FIREPLACE INSTALL 21

METHOD #5: ZERO-CLEARANCE FIREPLACE INSTALL 22

ADJUSTABLE CHIMNEY LENGTH 23

CHIMNEY MAINTENANCE 23

DURATECH®

CLEARANCES

Always allow at least a 2-inch clearance between DuraTech Chimney Pipe and any combustible materials. Combustible materials include lumber, plywood, sheetrock, plaster and lath, furniture, curtains, electrical wiring and building insulation. Keep single wall stovepipe at least 18 inches away from combustible materials, unless a clearance reduction system that is acceptable to the Authority Having Jurisdiction is used, or the appliance to be installed is listed and the instructions specify a different clearance.

NON-COMBUSTIBLE INSULATIONS

Non-combustible insulation is tested and approved through UL for use within the clearance to combustibles distance between a passthrough leading to the exterior of a building, and only as described in these instructions. The non-combustible insulation used must be listed / compliant with ASTM E136/ULC S114 as non-combustible, have a melting temperature above 2000°F/1100°C, be water resistant with low moisture absorption and be acceptable to the AHJ. Acceptable insulations include those made from stone (aka "rockwool" or "mineral wool" insulations).

Note - Fiberglass insulation is NOT approved!

PERMITS

Contact your local Building Official or Fire Official regarding permits, restrictions, and installation inspections in your area.

DURATECH CHIMNEY APPLICATIONS

DuraTech Chimney (5"-8" Dia) is a complete chimney system tested and listed to UL 103 HT for the United States, and ULC S604

in Canada. In the U.S., DuraTech 5"-8" Chimney can be used with wood stoves, fireplaces, fireboxes, furnaces, boilers, or other residential-type appliances fueled by oil, gas, coal, or wood, that require a UL103 HT chimney system. In Canada, DuraTech can be used with oil & gas fired appliances listed for use with a Type A Chimney, in accordance with ULC S604. DuraTech is also listed for use in Canada with some factory-built fireplaces; check with your fireplace manufacturer. Do not use with forced draft, positive-pressure appliances. The DuraTech Chimney system may have a maximum of two (2) offsets (four elbows total) of 30° from vertical.

INSTALLATION NOTES

You must use only authorized DuraTech Chimney parts to maintain a listed Chimney system (not including the connector pipe). Do not mix parts or try to match with other products, or use improvised solutions. Do not install damaged or modified parts. Follow the appliance manufacturer's instructions to determine: chimney diameter, clearances between combustible materials and your heating appliance, and to ensure maximum system efficiency and safety. Connect only one appliance per chimney. Never choose a chimney with an inside diameter smaller than your appliance's outlet. Practice good workmanship, sloppy work could jeopardize your chimney's safety. Keep electrical wiring and insulation away from all chimneys and stovepipes. If you have any questions, be sure to contact either your dealer or DuraVent directly.

Fuels: Do not burn driftwood, plastic, or chemically treated wood such as railroad ties. They are corrosive to your appliance, stovepipe and chimney. Follow the appliance

manufacturer's instructions and safety manual in regards to fuels. Not all appliances are equipped to burn coal. Coal with a low sulfur content will reduce the possibility of corrosion. Care must be taken to avoid over-firing, which can damage the appliance, stovepipe and chimney system.

Mobile Homes: Please read the appliance manufacturer's instructions and safety manual carefully. Not all appliances are listed for use in mobile homes.

CHIMNEY HEIGHT

The National Fire Protection Association Standard #211 states: "Chimneys shall extend at least three feet above the highest point where it passes through the roof of a building, and at least two feet higher than any portion of a building within ten feet." (**Fig.1**) DuraTech Chimney may be installed up to 60 feet high. If the chimney extends more than 5 feet above the roof, an Extended Roof Bracket must be used (see page 12). Due to the overlap of the joints, subtract 1-1/4 inches from each Chimney Section's height to calculate installed height.

CHIMNEY PLACEMENT

When deciding the location of your chimney, try to avoid modifications to roof beams and other structural components of the building.

CHIMNEY ENCLOSURE REQUIREMENTS

Through Rooms: Interior chimneys shall be enclosed where they extend through closets, storage areas, occupied spaces, or any place the surface of the chimney could be contacted by persons or combustible materials. Maintain at least a 2-inches of clearance between the outer wall of the chimney and the enclosure (**Fig.2**).

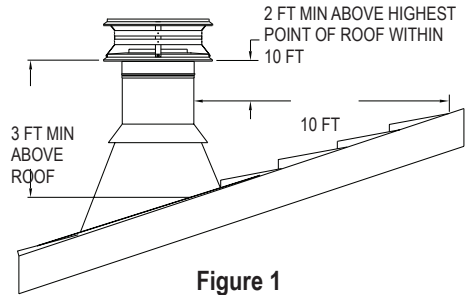

Figure 1

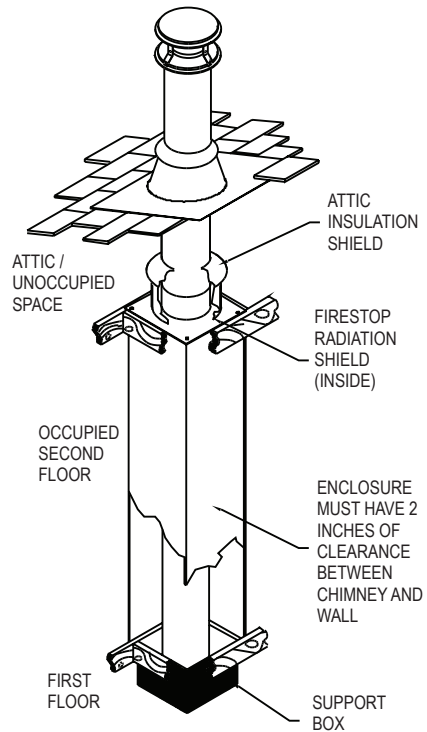

Figure 2

Multi-Story: Consult local building codes for requirements in your area. In the U.S., the National Fire Protection Association Standard #211 states: "Factory-built chimneys that pass through floors of buildings requiring the protection of vertical openings shall be enclosed with approved walls having a fire resistance

rating of not less than one hour when such chimneys are located in a building less than 4 stories in height, and not less than 2 hours when such chimneys are located in a building more than 4 stories in height.” In Canada, except in single-family and two-family dwellings, chimneys which extend through another story must have an enclosure with a fire resistance rating equal to or greater than that of the floor or roof assembly through which they pass.

Cold Climates: In cold climates, chimneys mounted on an outside wall should be enclosed in a chase. Exterior chases reduce condensation and creosote formation, and enhance draft. Include an access door by the Tee Cap for chimney cleaning (**Fig.26,27**).

TABLE 1: Framing Dimensions
Chimney Diameter

	5"	6"	7"	8"
CATHEDRAL CEILING SUPPORT BOX	11-1/4"	12-1/4"	13-1/4"	14-1/2"
FLAT CEILING SUPPORT BOX	11-1/4"	12-1/4"	13-1/4"	14-1/2"
ROUND CEILING SUPPORT BOX	11-1/4"	12-1/4"	13-1/4"	14-1/4"
FIRESTOP RADIATION SHIELD	11-1/4"	12-1/4"	13-1/4"	14-1/4"
WALL THIMBLE	11-1/4"	12-1/4"	13-1/4"	14-1/4"
CAS CEILING SUPPORT	NA	12-1/4"	NA	14-1/2"
CAS WALL THIMBLE	NA	12-1/4"	NA	14-1/4"
REDUCED CLEARANCE SUPPORT BOX	NA	10-1/4"	NA	NA

SUPPORT REQUIREMENTS

There are two “styles” of support connection to the chimney pipe: Dedicated dia supports, and Universal supports shown in **Fig.3 and 4**. For Universal components, the spacer is discarded for 5”-6” Dia. **Table 2** details the

TABLE 2: Chimney Support

DURATECH SUPPORT COMPONENT	CHIMNEY HEIGHT SUPPORTED 5”-8” DIA
ADJUSTABLE ELBOW STRAP	EA ELBOW/PIPE
ADJUSTABLE WALL STRAP	N/A - USE EVERY 8’ MIN
SUPPORT BOX (SQUARE OR ROUND)	60-FT
TEE SUPPORT	60-FT
EXTENDED ROOF BRACKET	N/A
EXTENDED WALL SUPPORT	20-FT
RE-SUPPORT	20-FT
ROOF SUPPORT	30’ TOTAL, 10’ ABOVE

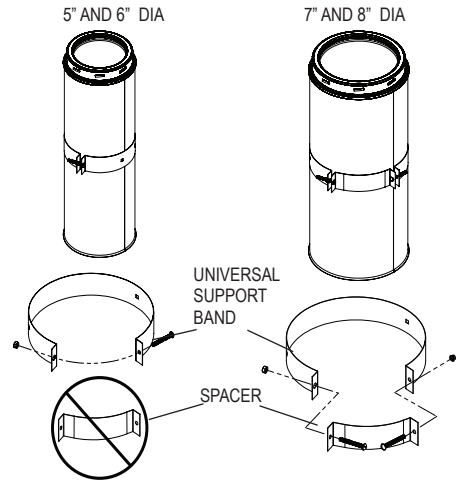

Figure 3

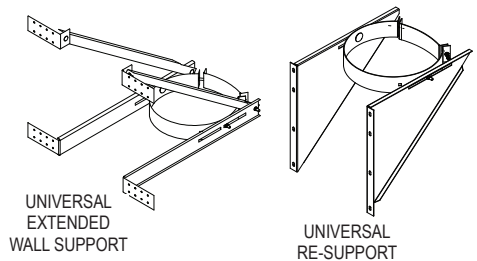

Figure 4

chimney height supported by the various components and must be followed throughout this instruction, this data applies to both styles. Items in Table 2 noted N/A are not load bearing components.

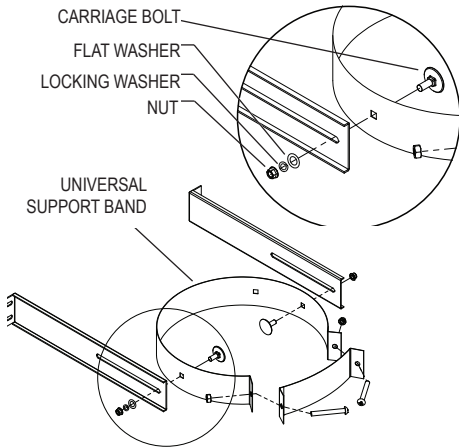

Figure 5

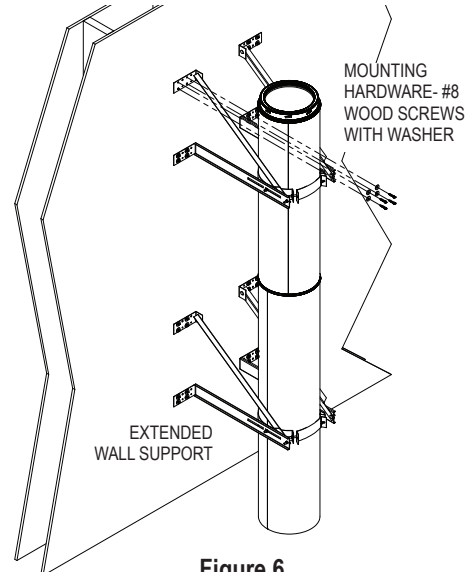

Figure 6

BAND-BRACKET CONNECTIONS

For Universal components, use the carriage bolt through the band and through the leg. Use (1) flat washer, (1) locking washer, and (1) nut per side to secure to carriage bolt (Fig.5). Ensure carriage bolts are directly across from each other.

WALL SUPPORTS/RE-SUPPORTS

Wall Supports, Re-Supports, and Tee Supports can be used interchangeably (Fig.6) to support the chimney on vertical runs.

STEP-BY-STEP DIRECTIONS

There are five general types of DuraTech Chimney installations- Review the step-by-step directions before beginning your installation.

- 1.Ceiling-supported (p.7)
- 2.Roof-supported (p.14)
- 3.Tee-supported-through-the-wall (p.16)
- 4.Masonry Fireplace (p.20)
- 5.Zero-Clearance Fireplace (p.21)

METHOD 1: CEILING SUPPORTED

1. Place Appliance: Position the appliance according to the manufacturer's instructions. The flue outlet collar should be placed between the rafters or joists above, if possible.
2. Frame Support Opening: Drop a plumb bob to the center of the appliance's flue outlet and

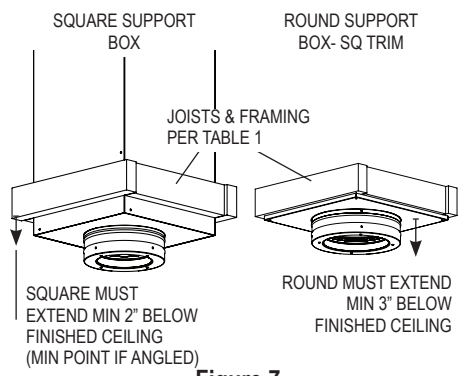

Figure 7

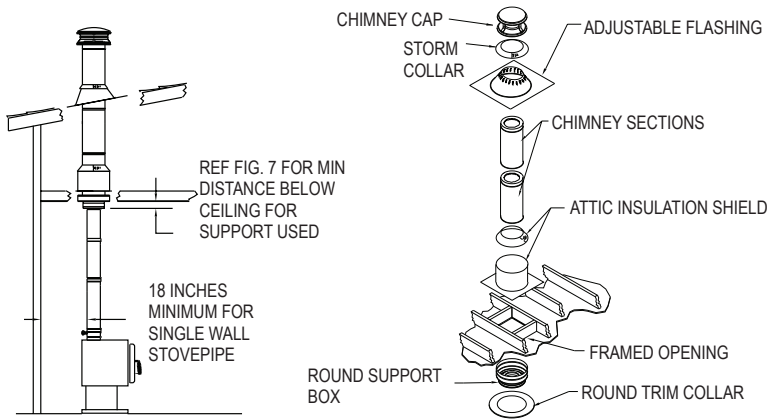

Figure 8

mark this center point on the ceiling. Refer to **Table 1** for specific framing and clearance dimensions. Mark appropriate cutting lines around the center point. Cut a square hole in the ceiling for the Support Box. Frame a level, square opening centered over the hole which you have cut. (**Fig.7 and 8**).

3. **Install Support Box:** For installation into a flat ceiling, there is the option of the Round Support Box (Round or Square Trim Collar), Flat Ceiling Support Box, Square Ceiling Support Box, or Reduced Clearance Support Box. The Flat Ceiling Support Box is primarily used for Oil Appliances and comes unpainted. For the Round support box, the trim mounts flush to the ceiling with the bottom protruding a min of 3" below the ceiling (**Fig.7**). For the Square support box, the square face must protrude a min of 2" below the ceiling (**Fig.7**). Level the Support Box and secure it to the framing using at least three 8-penny nails per side (min. of 12 total). Alternatively, you may use 1-1/2" #8 wood screws (min. of 12 total), instead of nails. After the Support Box is mounted, secure the Trim Collar (round or square) to the framing members using the (4) 1" long, round-head wood screws provided

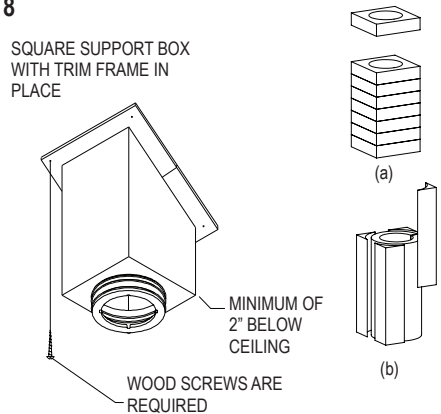

Figure 9

(**Fig.9**). For installation into a cathedral ceiling, you must use the Square Ceiling Support Box or Reduced Clearance Support Box and the two-piece Trim. The bottom of the square portion of the Support Box must be a minimum of 2" lower (round portion is then an additional 3" lower) than the finished ceiling at the lowest side of the penetration (**Fig.9**). Level the Support Box and secure it to the framing using at least three (3) 8-penny nails per side (minimum of 12 nails total), or a minimum of (3) #8, 1-1/2" wood screws. Adjust the overlapping "U-shaped" Trim pieces so they cover the Support Box, and secure them to the

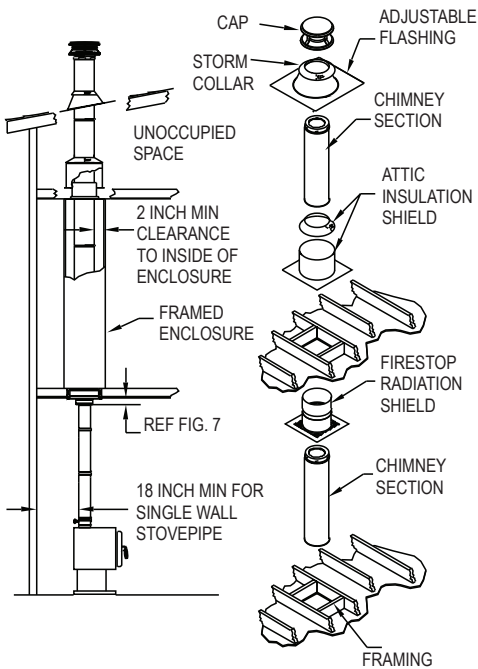

Figure 10

framing members using the (6) 1-1/4" round head wood screws provided (**Fig.9**).

• **3-A.** When installing a Support Box into a roof, non-combustible insulation adhering to the specifications on page 4 may be added to prevent cold/outside air intrusion and limit condensation on the surface of the Support Box. Cut the insulation into squares as shown in **Figure 9a**, or wrap the pipe with an insulation blanket and fill in the corners as shown in **Figure 9b**. Do not compress the insulation more than 25% or you may adversely affect the thermal resistance of the insulation. Non-combustible insulation is allowed up to the top edge of the Support Box, but not go past the edge where it can fall out or come in direct contact with combustible materials.

4. **Frame Openings:** Frame openings in each ceiling or floor above the Support Box (**Fig.10**). These openings are to hold the Firestop Radiation Shield and Attic Insulation Shield. Locate each opening by dropping a plumb bob to the four corners of the opening below. Maintain the framing dimensions as specified in **Table 1**. **Warning: other than the framing for the Reduced Clearance Support Box, any combustible materials around the chimney must meet the minimum 2" clearance requirement.** If Elbows must be used to avoid an obstruction, refer to the Offset Elbow Installation section.

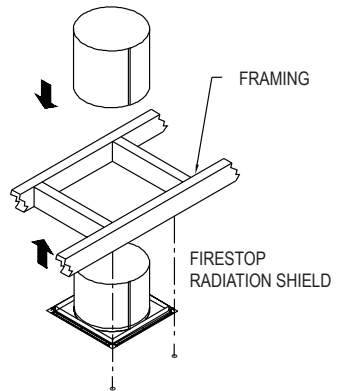

Figure 11

5. **Cut Roof Opening:** Cut an opening in the roof directly above the opening below, and at least 4" larger than the chimney's outside diameter to provide at least a 2" clearance all around the chimney. The chimney must be centered within this opening and maintain the 2" clearance to combustibles.

6. **Install Firestop Radiation Shield:** A Firestop Radiation Shield is required in multistory installations at each floor penetration above that where the Support Box is located. Example: in a multistory home where the appliance is on the ground floor (Support

Box is in the 1st floor ceiling), you would need a Firestop Radiation Shield at the 2nd floor ceiling, and at the 3rd floor ceiling, etc., including where the chimney penetrates into the attic. **Fig.10** shows a typical 2-story installation with an attic. Note: a Firestop Radiation Shield is not installed where the chimney penetrates through the roof. The Firestop Radiation Shield is installed on the underside of the ceiling/floor framing, with the cylindrical “tube” portion of the shield pointing upward. (**Fig.11**). Use a minimum of either (1) 8 penny nail or (1) #8, 1-1/2” wood screws per corner. Refer to **Table 1** for framing requirements.

7. Assemble Chimney Sections: Lower the female end of the first Chimney Section in the Support Box (**Fig.12**). It will twist-lock clockwise onto the male end of the Support

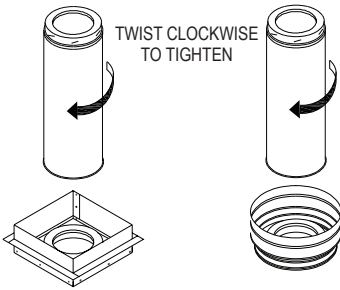

Figure 12

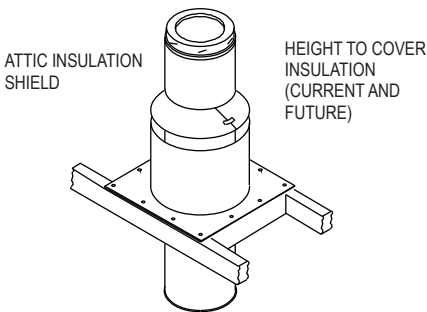

Figure 13

Box. Turn Pipe Sections firmly clockwise to lock them together. Sheet metal screws are not required, but they may be used to reinforce the connection, if desired. Use only 1/2” (or shorter) sheet metal screws. Do not penetrate the inner liner of the chimney.

8. Install Attic Insulation Shield: The Attic Insulation Shield is required where an unenclosed chimney passes into an unoccupied space. Its purpose is to prevent current and future combustibles (debris, non-approved insulation, etc.) from getting too close to the chimney (**Fig.13**). An installed Attic Insulation Shield must be high enough to cover current or future insulation. In unoccupied areas where this shield cannot fit, you must enclose the chimney in a framed enclosure. If the chimney is fully enclosed through the unoccupied space, an Attic Insulation Shield is not required. If the installation requires the Attic Insulation Shield, follow the below guidance:

- 8-A. For a 6” Dia DuraTech Chimney system, if the unoccupied space is immediately above the square or round support box (if used), the support box may be used as an Insulation shield, using the included collar to completely cover the support box. If desired, non-combustible insulation may be inserted into the Support Box as described in step 3-A. Important: Ensure support box height is appropriate to cover current/future insulation height.
- 8-B1. On Multi-Story installations and diameters other than 6”, if the Firestop Radiometer Shield extends above the unoccupied floor, no modifications are necessary. The Firestop Radiation Shield will fit inside the stand alone Attic Insulation Shield.
- B2. Assemble Chimney Sections until at least 18 inches of chimney extends above the Firestop Radiation Shield.

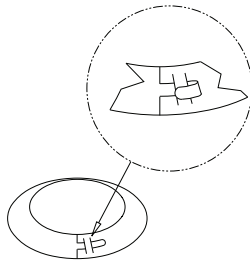

Figure 14

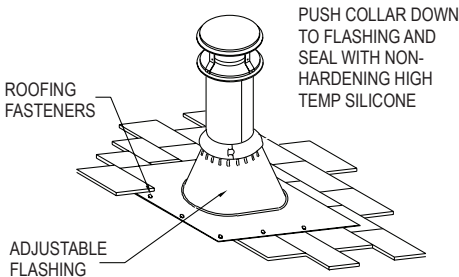

Figure 15

B3. Extend the Firestop Radiation Shield tube extension (keep at least 1" overlap), and secure in place using sheet metal screws.

B4. Slip the Attic Insulation Shield over the Chimney and Firestop Radiation Shield until the base sits squarely on the framed opening (**Fig.10, 13**). If desired, non-combustible insulation may be installed in the Attic Insulation Shield. Before installing, add a 2" thick blanket of insulation around the inside of the Attic Insulation Shield, then slip over the Chimney.

B5. Secure the Attic Insulation Shield to the top of the framed opening using at least (3) 8-penny nails or (3) #8, 1-1/2" wood screws per side (**Fig.13**).

B6. Wrap the Collar of the Attic Insulation Shield around the chimney and fasten it loosely. Slide the Collar down to meet the Attic Insulation Shield. Slip the tab through the adjacent slot and fold it back to tighten and secure the Collar (**Fig.14**).

9. **Spray Foam Insulation Shield:** A Spray Foam Insulation Shield is necessary whenever spray foam is used to insulate the roof rafters. Install the Spray Foam Insulation Shield in the same way as a Support Box, however only 1 screw or nail per side is needed. The Spray Foam Insulation Shield may be insulated with non-combustible insulation as specified.

10. **Attach Flashing:** In new construction, assemble the Chimney Sections to a point above the roof, then slip the Flashing over the chimney. On an existing roof, center and install the Flashing before extending the chimney above the roof. Allow space to permit sliding the next Chimney Section up through the Flashing. Always insure the chimney remains vertical (use a level), and that at least a 2" clearance to combustible materials is maintained all around. Install the upper edge of the Flashing under the roofing. Nail to the roof along the upper edge and down each side with 1" roofing nails. Do not nail the lower edge of the Flashing (**Fig.15**). Seal top and upper sides of flashing with roofing compound or sealant. Be sure to follow local building practices, as needed. Seal all nail heads with a non-hardening waterproof sealant. On flat or tarred and graveled roofs, nail and seal the Flat Roof Flashing to the roof on all sides with roofing compound. Do not put screws through the Flashing into the Chimney Pipe.

11. **Finish Top:** Apply a high-temperature (500°F), non-hardening waterproof sealant around the chimney at the point where the Storm Collar will meet the chimney just above the Flashing (**Fig.15**). Slide the Storm Collar down over the chimney to the top of the Flashing. Tighten and seal the Storm Collar against the sealant. After installing sufficient Chimney Sections to meet the height requirement (**Fig.1**), attach the Chimney Cap onto the top of the chimney by holding the

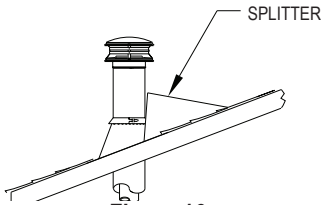

Figure 16

collar of the cap and twist locking it clockwise onto the chimney. Do not hold upper portion of the cap and twist, as this may damage the cap. The Chimney Cap can be removed for chimney cleaning as described in the Chimney Maintenance section of the instructions. Use an Extended Roof Bracket if the chimney extends more than 5' above the roof (**Fig. 18 in the Extended Roof Bracket section**). If you are located in heavy snow country, it is recommended that a Snow Splitter be installed (**Fig. 16**). This will help protect the chimney by routing snow around it.

12. **Enclosures:** Enclose chimneys where they pass through occupied spaces, including closets. Always maintain at least a 2" clearance between the chimney and any combustible materials. Interior enclosures may be constructed with standard framing and sheathed with sheetrock or plywood. **Important: Use Wall Straps every 8' min to maintain a minimum of 2" of air space between the chimney and combustible materials.**

OFFSET ELBOW INSTALLATION

Elbows are manufactured in 15° and 30° angles measured from the vertical. In the US, a 30° Elbow is the largest that can be used in an offset. A 30° Elbow may not be combined with a 15° Elbow to make a 45° offset. Elbows inhibit draft, avoid their use where possible. When Elbows are necessary to avoid obstructions such as rafters, etc, use no more than 2 pairs of Elbows in any one chimney system.

1. **Attach Elbows:** Attach Elbow to Chimney Section or other Elbow by twisting clockwise until they lock firmly. Attach one Elbow to the Chimney Section below, and align it for the offset. Elbows for DuraTech have a swivel feature that allow for 360° rotation at their base for ease of installation. Refer to **Table 3** to determine the required offset length and attach an appropriate length (or lengths) of Chimney Section(s) above the Elbow. **Important:** For each chimney pipe section in the offset

TABLE 3: Offset Chart

Elbow Angle from Vertical	Chimney Length Between Elbows	Offset Inches	Rise Inches
15"	0"	2"	16 ½"
15"	6"	3 ¼"	21 ¼"
15"	12"	4 ¾"	27"
15"	18"	6 ¼"	32 ¾"
15"	24"	8"	38 ½"
15"	36"	11"	50 ¼"
15"	48"	14 ¼"	61 ¾"
15"	48" + 6"	15 ½"	66 ½"
15"	48" + 12"	17"	72 ¼"
15"	48" + 18"	18 ½"	78"
15"	48" + 24"	20"	83 ¾"
30"	0"	4"	15 ¾"
30"	6"	6 ¼"	
30"	12"	9 ¼"	25 ¼"
30"	18"	12 ¼"	30 ¼"
30"	24"	15 ¼"	35 ½"
30"	36"	21 ¼"	46"
30"	48"	27 ¼"	56 ¼"
30"	48" + 6"	29 ¾"	60 ½"
30"	48" + 12"	32 ¾"	65 ¾"
30"	48" + 18"	35 ¾"	71"
30"	48" + 24"	38 ¾"	76"

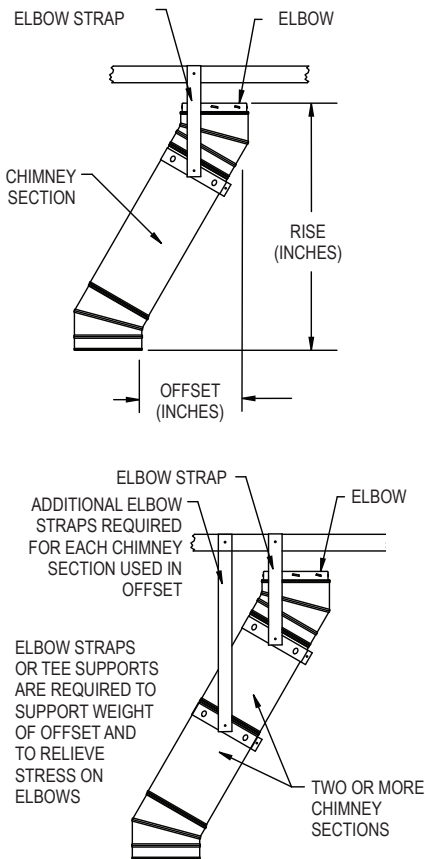

Figure 17

(between the elbows), there must be an Elbow Strap, Tee Support, or similar support method to support the weight of the pipe and to relieve stress on the Elbows. Attach the second Elbow above the Chimney Section to complete the offset (**Fig.17**).

2. Secure Offset: Place the Elbow Strap's band around the angled portion of the top Elbow, then tighten the nut and bolt until the clamp is firm. There are both dedicated diameter, and Universal components available, Wrap the Elbow Strap end over an adjacent joist or rafter and secure it with at least (2)

8-penny nails or (2) #8, 1-1/2 screws. Do not add more Chimney Sections until the Elbows are supported. Be sure that the chimney remains vertical. If there is more than one Chimney Section between the Elbows, install a second Elbow Strap around the joint of the two Chimney Sections (**Fig.17**).

EXTENDED ROOF BRACKET INSTALLATION

If the chimney extends more than 5' above the roofline, an Extended Roof Bracket must be installed at every 5' increment of chimney height above the roofline, leaving no more than 5' of chimney extending above the last pipe bracket. The Extended Roof Bracket consists of the Pipe Band, the Adjustable Legs, and the Roof Brackets.

1. Mount Pipe Band: Slip the Pipe Band around the chimney and secure by tightening the nut and bolt.
2. Attach the Legs: The Adjustable Legs of the assembly will adjust from 67" to 114". Secure one end of each Leg to the Pipe Band using the nuts and bolts included (2 per Leg). Position the Adjustable legs so they form

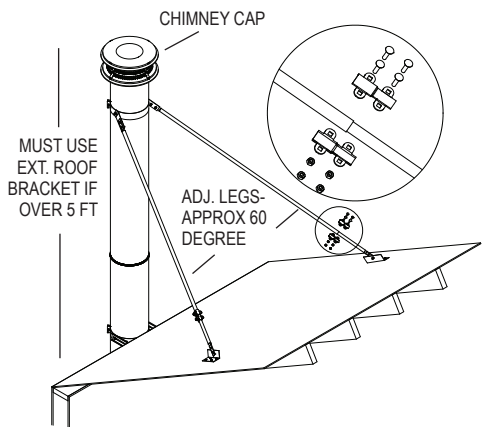

Figure 18

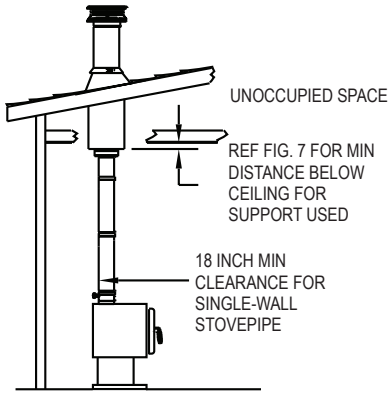

Figure 19

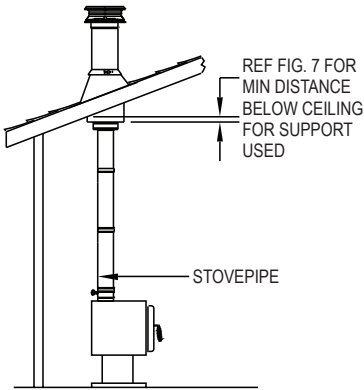
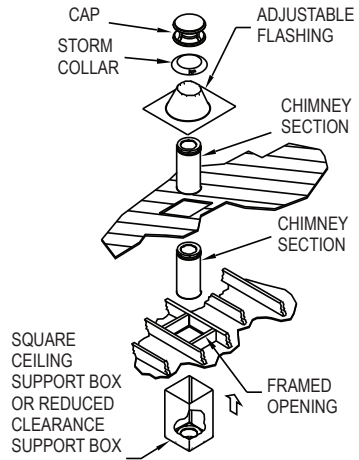
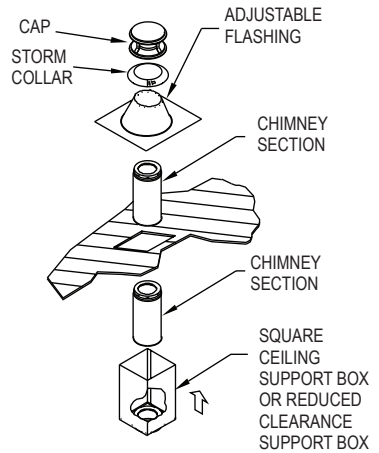

Figure 20



approximately a 60° angle with the chimney, and with each other (**Fig.18**). Be sure that there is at least 3” of overlap between the top and bottom halves of the Adjustable Leg. In order to secure Legs in proper position, there is a hole provided in the outer leg where the outer and inner halves overlap. Use a 1/4” drill bit to drill through the inner leg at that location. Use the nut & bolt provided to pin the Adjustable Legs in position.

3. **Install Roof Brackets:** Mount the two Roof Brackets where each of the Adjustable Legs meets the roof, using (4) 1” roofing nails or screws per bracket. Seal the nail heads carefully with a non-hardening, waterproof sealant. Attach the bottom end of the Adjustable Legs to the Roof Brackets using the nuts & bolts provided.

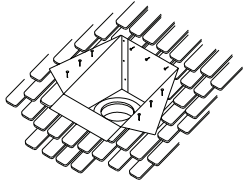

Figure 21

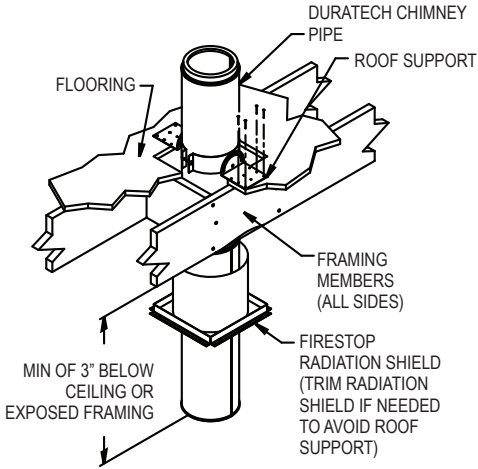

Figure 22

METHOD 2: ROOF SUPPORTED INSTALLATIONS

There are two types of Roof Supported Installations: (A) Using a Square Ceiling Support Box or Reduced Clearance Support Box and (B) Using a Roof Support.

(A) Support Box: For a Square Ceiling Support Box or Reduced Clearance Support Box, make sure that the square box portion of the Support Box can extend at least 2" below the low side of the finished ceiling (**Fig.7, 19**). The Support Box must remain level, and the top edge of the box must cover the edge of the roof's decking material. Mobile home chimney installations are roof supported.

A1. Place Appliance, Frame Opening: Follow Step 1 and 2 from "Ceiling-Supported" method detailed earlier. Refer to **Table 1** for clearance and framing specifications. If it is desired to install through a cathedral ceiling (**Fig.20**), then the hole is cut in the roof. If a separate ceiling and roof exists, as shown in **Fig.19** (Low Attic), first cut and frame a ceiling opening as in "Ceiling-Supported" Step 2.

A2. Install Support Box: Slip the Square Support Box or Reduced Clearance Support

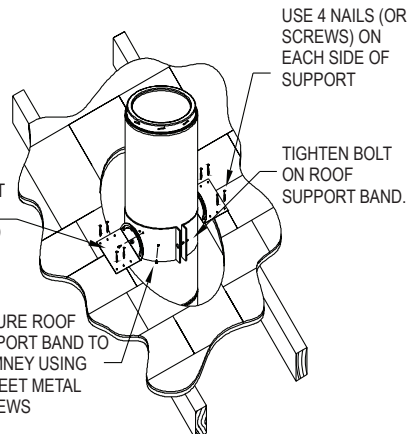
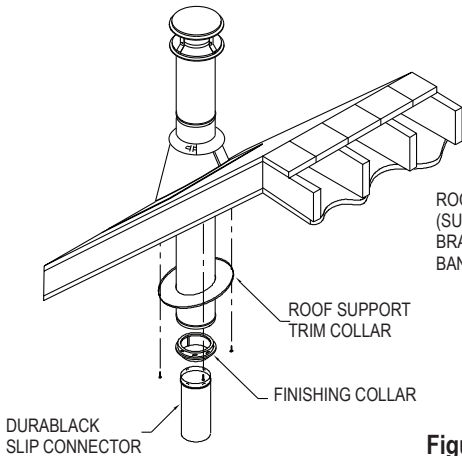

Figure 23

Box into the framed opening so the square portion projects at least 2" below the finished ceiling and rafters (bottom of round portion is 5" below, **Fig.7**), and extends above the ceiling to framing or decking materials to which it can be nailed. Level the Support Box, and slit the corners to the roofline where they extend beyond it. Bend the flaps (created by the slitting) flush with the roof, and nail the Support Box to the roof or framing with at least three (3) 8-penny nails, or (3) 1-1/2", #8 screws, per side (**Fig.21**). Be sure to keep the Support Box level. Screw the trim sections into the ceiling (**Fig.9**). Refer to step 3-A of the Ceiling Supported Installation instructions if you choose to insulate the Support Box.

A3. Complete Installation: Refer to Steps 7, 9 & 10 in the "Ceiling Supported" section to complete the Roof Supported install. Non-combustible insulation as specified on page 4 may be added to the Support Box.

(B) Roof Support: A Roof Support may be used in installations where there is a cathedral ceiling, and a Square Ceiling Support is not desired. The Roof Support allows the DuraTech chimney to come down into the room below the level of the ceiling (**Fig.23**). The Roof Support can support a maximum of 30' of DuraTech Chimney total, with maximum of 10' above the support (**Table 2**). If a taller stack of DuraTech Chimney is required, you must use a Square Ceiling Support Box instead.

B1. Place Appliance: Step 1 from "Ceiling-Supported" method detailed earlier.

B2. Cut Openings: Cut and frame openings to provide a minimum 2" clearance on all sides of the chimney pipe. Note: Opening in finished ceiling should be circular/oval in order for it to be covered by Trim Collar.

B3. Install Roof Support: Bolt on the Roof Support Brackets to the Roof Support Band using the supplied hardware. Attach the Roof

Support Brackets to roof using (4) 8 penny nails or (4) #8, 1-1/2" screws per side (**Fig.23**).

B4. Assemble Chimney Sections: Determine how much DuraTech Chimney will be extending into the room (minimum of 3" below the ceiling). Be sure to maintain the proper clearance to combustibles (walls and ceilings) for the connector pipe. Once you have identified the proper height for your installation, attach the Roof Support Band to the Chimney Section by tightening the Bolt, and secure it by using (4) supplied sheet metal screws. Attach desired length of Chimney above the roof level, max. of 30' total, 10' above the support (**Table 2**).

B5. Transition to Connector Pipe: Attach the Finishing Collar by twist locking it to the bottom section of DuraTech Chimney. Then, slide Trim Collar over the DuraTech Chimney and attach the Trim Collar to the ceiling using (4) 1-1/4" screws provided (**Fig.23**).

B6. Finish Installation: Refer to Steps 10 & 11 in the "Ceiling Supported" section to complete the Roof Supported installation.

Alternative Installation for Roof Support:

The Roof Support may be used at the bottom of a Chimney installation (**Fig.22**). This may be useful for some basement installations. Maintain a minimum of 2" clearance to combustibles at all times. The DuraTech Chimney needs to extend a minimum of 3" below the finished ceiling or exposed framing members. Please note that you cannot extend the chimney all the way to the appliance - you must use connector pipe.

1. Complete Steps B1-B3 from Roof Support Section. For Step B3, rather than installing the Roof Support on the roof, attach the Roof Support Brackets to floor using (4) 8 penny nails or (4) #8, 1-1/2" screws per side (**Fig.22**).

2. Complete Step B4 from Roof Support Section.

3. Install a Firestop Radiation Shield below the finished ceiling or framing members. Trim the 'tube' portion of the Firestop Radiation Shield as needed if it interferes with the Roof Support Installation (**Fig.22**).

4. Follow steps B5 and B6 from the Roof Support section.

Note: Non-combustible insulation is not approved for use with Roof Supported installations.

METHOD 3: TEE-SUPPORTED INSTALLATIONS

Tee-Supported installations are used when passing through a wall to a chimney. The Tee Support can hold a maximum of 60' of DuraTech Chimney (**Table 2**). The various support components are adjustable in length from the wall to better fit your installation. There are two options when installing a Tee-Supported installation: the Tee Support above the Tee, or the Tee Support below the Tee. The required parts and general configuration are as shown in **Fig.24, 25, 26 and 27**.

1. Place Appliance: Follow Step 1 from "Ceiling-Supported" method detailed earlier.
2. Locate, Cut & Frame Opening: Determine the location where the chimney will pass through the wall. The chimney should pass through the wall, centered between two studs. The height of the penetration can be determined by positioning sections of stove pipe until you have the desired configuration (refer to the appliance manufacturer's installation instructions for restrictions on stove pipe). Cut and frame an opening in the inner and outer walls at this location. Refer to **Table 1** for the appropriate framing dimensions.
3. Install Wall Thimble: The Wall Thimble is a two-piece component which includes the Interior half and the Exterior half. On the outside wall, install the back portion of the Wall

Thimble. Center the back portion of the Wall Thimble (with shield inside wall) in the framed opening of the outside wall (**Fig.24**). Be sure to seal the flange of the Wall Thimble around the wall by using a non-hardening waterproof sealant. Attach the back portion of the Wall Thimble to the outside wall using at least (4) 8-penny nails or (4) #8, 1-1/2" wood screws. There must be a continuous shield within the wall. If the two halves of the Wall Thimble do not overlap, a field-fabricated extension constructed out of 26-gauge galvanized or stainless steel is needed. Non-combustible insulation that adheres to the specifications outlined on page 4 may be inserted into the Wall Thimble. Do this by wrapping an insulation blanket around the pipe between the thimble sleeves. Ensure the butting edges of insulation are pointing downward. Smaller pieces of insulation may be used to fill in the corners of the thimble pass-through. Do not compress the insulation more than 25% or you may adversely affect the thermal resistance of the insulation.

4. Install Tee Support: Install the Tee Support on the outside wall. Position Tee Support so that the chimney Tee will be centered inside the Wall Thimble (**Fig.24, 25, 26 & 27**). The Tee Support may be installed either above the Tee or below the Tee (within one pipe section), as seen in **Fig.25**. See **Table 2** for weight bearing values of components. Important: Verify that Tee Support is level, and secure the Support to the wall using (4) #8, 2-1/2" screws for each side. Slide support base over leg brackets to adjust for desired clearance to wall, and secure by tightening bolts (**Fig.24 & 25**).
5. Install Tee and Cleanout Chimney Section: Twist lock the Tee onto a desired length of Chimney to be used as the cleanout section. Use only one chimney section (any length) to attach to bottom of the Tee. Tighten support band around chimney section at proper height

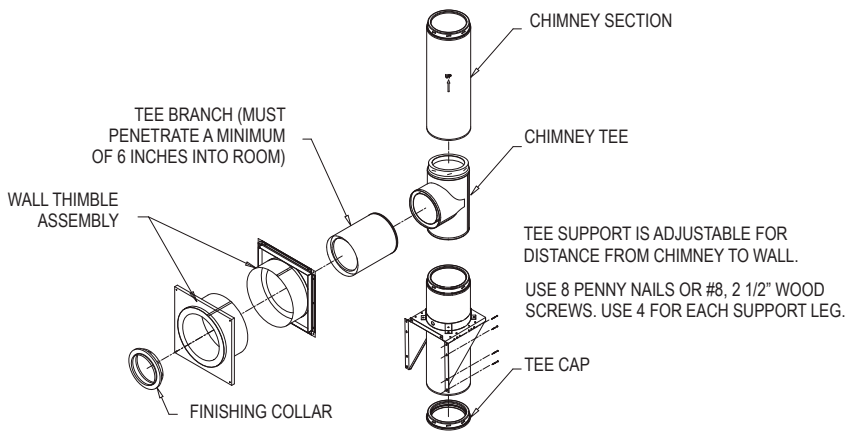

Figure 24

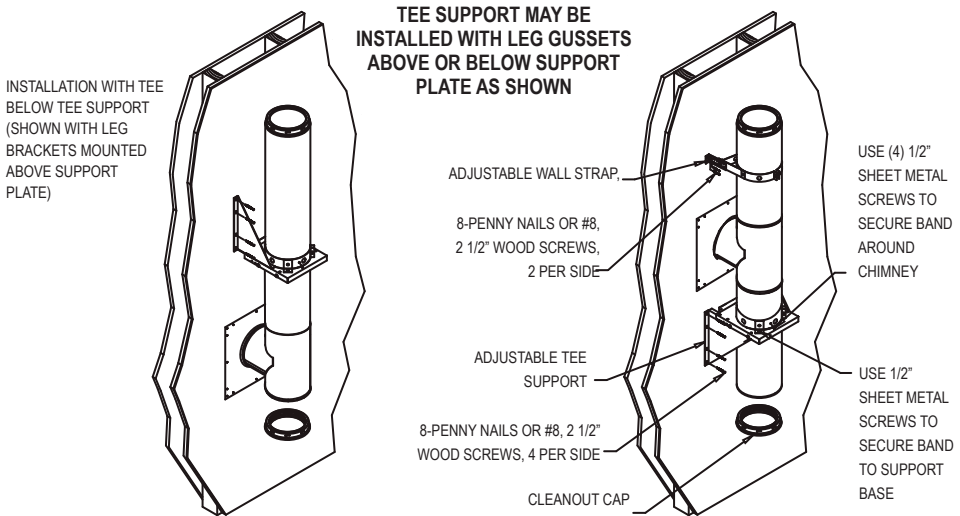

Figure 25

to insure that Tee is centered through Wall Thimble (**Fig.25**). Use the 1/2" sheet metal screws provided to insure a tight connection between support band and chimney section. Connect support band to support base using the 1/2" sheet metal screws provided (**Fig.25**). Twist lock Tee Cap into bottom of Chimney

Cleanout section.

6. Install Branch onto Tee: From inside the house, attach the Chimney Branch up to 24" chimney section, depending on wall thickness, positioned horizontally used to pass through the wall) to the Tee by twist locking it clockwise. Important: The Chimney section

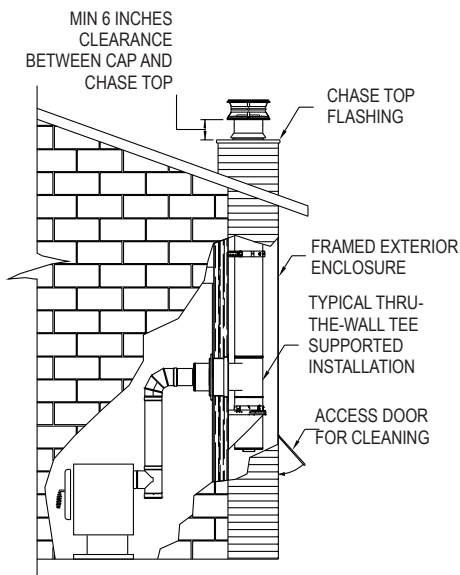

Figure 26

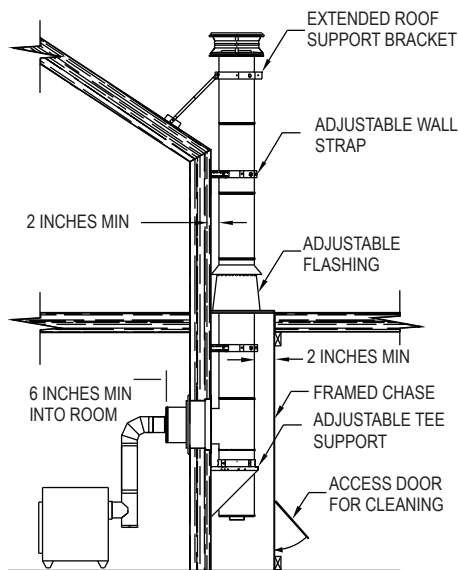

Figure 27

used to penetrate through the wall must extend at least 6" into the room (**Fig.24 & 27**). Use high-temperature sealant (500°F) to seal between the Wall Thimble and the Chimney on the outer wall.

7. Install Cover Plate and Finishing Collar:

After the Chimney Branch is secured in place (penetrating at least 6" into the room), slide the Cover Plate over the Branch and attach it to the framing using (4) 1-1/4" long, round head wood screws. Be sure that the Branch is centered in the opening of the Cover Plate. Twist lock the Finishing Collar on to the female end of the Chimney Branch by twisting clockwise.

8. Complete Chimney: Attach the Chimney Sections as in Step 7 in the Ceiling Supported Installation section. Secure the chimney to the wall with Wall Straps at a minimum of 8' intervals and maintain at least 2" of clearance to combustible materials. The various support components are adjustable in length from

the wall to better fit your installation. Slip the Wall Straps around the chimney, tighten the bolts, adjust the clearance, and fasten the Wall Straps to the wall with (4) #8, 1-1/2" long wood screws. Once the chimney is at the minimum height specified in **Fig.1**, attach the Chimney Cap onto the top of the chimney by holding it by the collar and twist locking it clockwise onto the Chimney Pipe. If the chimney penetrates an overhang, frame for at least 2" of clearance, and install Flashing and Storm Collar as described in Steps 9 & 10 for "Ceiling Supported" Installations. Another option is to cut away the overhang for a 2" clearance (**Fig.28**). If the chimney extends more than 5' above the top Wall Strap or Flashing, use an Extended Roof Support Bracket.

9. Install Chase Top Flashing: It is recommended that a Tee Supported Chimney be enclosed in a chase. If a chase enclosure has been constructed, you can either use a standard flat-roof flashing, or you can use a Chase Top

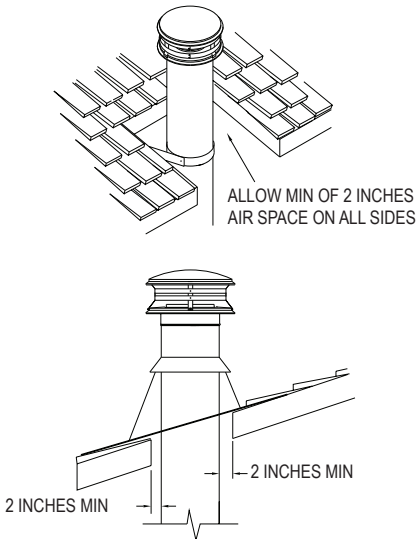

Figure 28

Flashing. Using a Chase Top Flashing allows for a lower profile for the chimney. The Chase Top Flashing has an opening that is 3" larger in diameter than the DuraTech Chimney. If the Chase Top Flashing can fit over your chase enclosure as required (**Fig.29**) then install as directed, or trim as needed. However, if the Chase Top Flashing is smaller than your chase enclosure, you will need to provide a galvanized sheet capable of covering your chase and overhanging the sides by 1/2 - 3/4 inch. Attach the Chase Top Flashing to the galvanized sheet using appropriate sheet metal screws and non-hardening waterproof sealant. Use the Chase Top Flashing Spacers to allow the proper air-gap clearances on the galvanized sheet. The Chase Top Flashing Spacers are available to insure that the proper air-gap is maintained. **Fig.29** displays how these air gaps are established using the Spacers and Chase Top Flashing. Secure

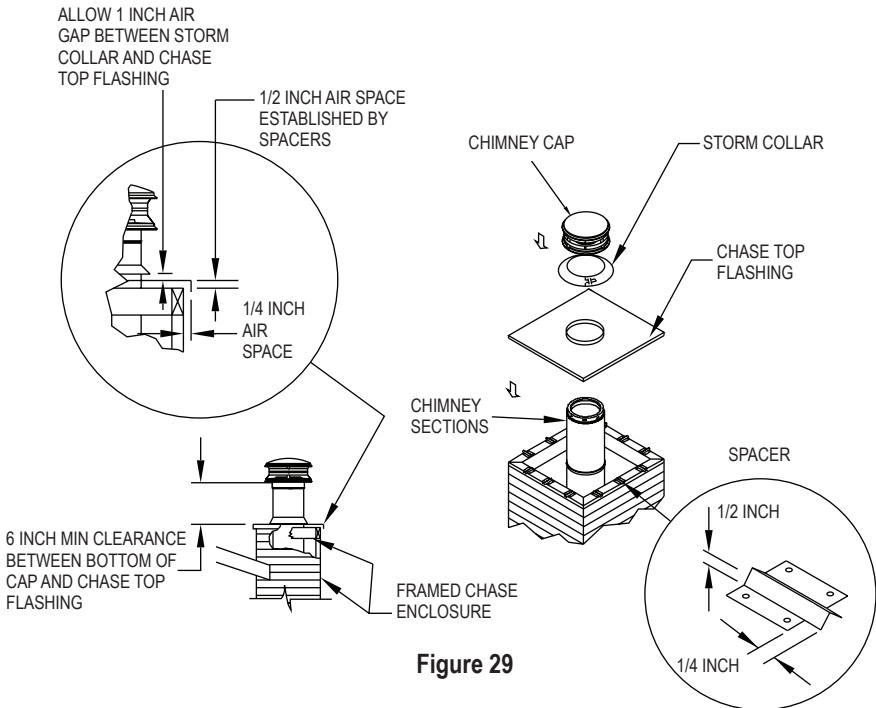

Figure 29

the Chase Top Flashing to the chase using a sufficient number of #8, 1-1/2" wood screws, ensure the air gap is maintained between the flashing and the chase. Seal the screw heads with non-hardening sealant. When installing the Storm Collar, allow a 1" air space between the bottom of the Storm Collar and the Chase Top Flashing. **Note: Non-combustible insulation is not approved for use at the Chase Top.**

METHOD 4: MASONRY FIREPLACE INSTALLATIONS

1. Determine Chimney Size: Use **Fig. 30** to determine the correct diameter chimney for your fireplace.
2. Mount Anchor Plate: Chimneys for masonry fireplaces begin with an Anchor Plate. Make sure the surface of the masonry chimney has a level surface on which to attach the Anchor Plate. If the top of the masonry does not have a level surface, then you will need to modify the

masonry accordingly. Follow the requirements of your local building department for connecting factory-built chimneys to masonry fireboxes or masonry chimneys. Center the Anchor Plate over the masonry flue opening, and seal the Anchor Plate with a high-temperature (1000°F) sealant. Secure Anchor Plate with at least (4) 1/4" x 4" masonry anchors (**Fig. 31**). It is very important that the Anchor Plate is level. *Be sure to maintain a 1" min. clearance to combustibles from the Anchor Plate.*

3. Attach Chimney: Twist lock the first Chimney Section clockwise onto the Anchor Plate.
 4. Finish Chimney: Install the rest of the chimney as directed in the Ceiling Supported Installation section, Steps 4 through 10
- Refer to Fig. 1, Fig. 30 for chimney height requirements.** Always maintain at least 2" of clearance to combustible materials, and enclose the chimney where it passes through occupied areas. Use a Wall Strap for every 8' of chimney

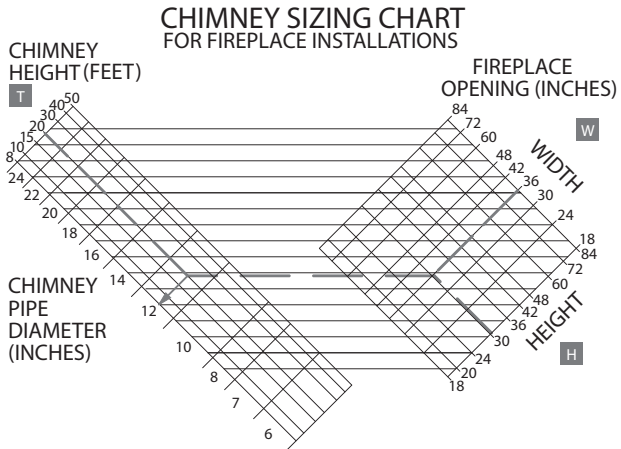
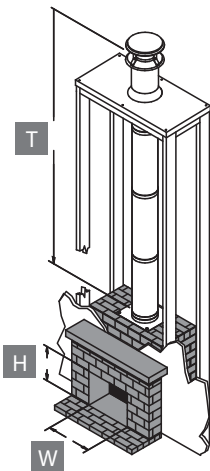

Dotted line represents sample problem. Example shows fireplace opening as 36" wide and 30" high, and the chimney height as 20'. The correct flue size for the sample problem is 12" diameter pipe.

Figure 30

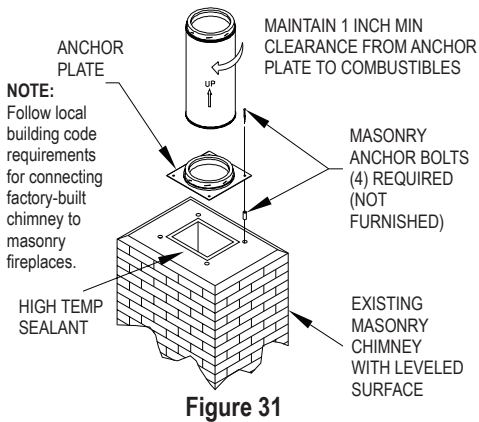

Figure 31

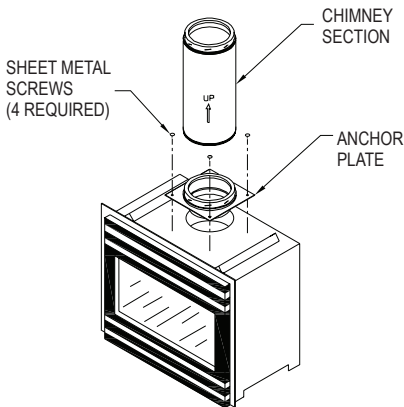

Figure 32

height.

METHOD 5: ZERO-CLEARANCE FIREPLACE INSTALLATIONS

1. Manufacturer's Instructions: Carefully read and comply with the manufacturer's installation instructions for your fireplace. Be sure that DuraTech is approved for use with your appliance.

2. Anchor Plate: Attach an Anchor Plate to the fireplace top with (4) 5/8" sheet metal screws (**Fig.32**). Check with the appliance manufacture about the use of high temperature sealants.

3. Chimney Sections: Attach a Chimney Section to the Anchor Plate by twist-locking clockwise.

4. Completion: Install the remainder of the chimney as instructed for a standard Ceiling-Supported installation, (using a Firestop Radiation Shield in the 1st floor ceiling instead of the Support Box). Always maintain at least 2" of clearance to combustibles, and enclose the chimney where it passes through occupied areas.

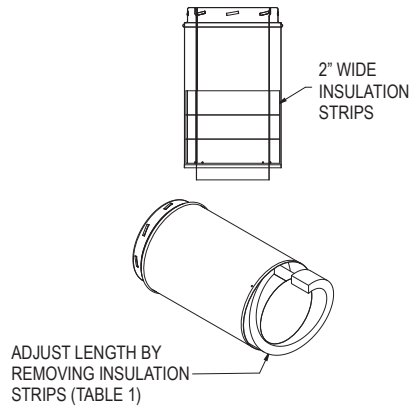

Figure 33

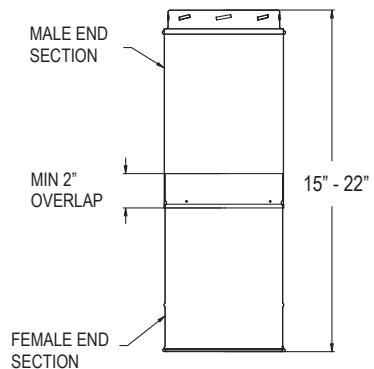

Figure 34

ADJUSTABLE CHIMNEY LENGTH

The DuraTech Adjustable Length is used when an exact length of chimney is needed and standard lengths of chimney are not sufficient. The Adjustable Length spans from 15"-22" (**Fig.34**) and can be used between any other DuraTech chimney sections (straight pipe lengths, elbows, tees, etc.).

1. Determine the length needed for your installation. There will be 1-1/4" lost to the joint between the Adjustable piece and the next section of chimney.
2. Remove insulation strips from male end

Required Total Length	Insulation Removed
20" - 22"	0 strips removed
18" - 20"	1 strip removed
16" - 18"	2 strips removed
14" - 16"	3 strips removed

of pipe, as needed, depending on the length required for your installation (**Fig.33**). Be very careful on how much, if any, insulation is removed from the male section. Refer to **Table 4**.

WARNING: The entire Adjustable Length must be filled with insulation, without gaps. Failure to ensure the insulation is continuous can result in a fire hazard.

3. Slide the two sections of the Adjustable Length together, compressing the insulation to achieve the desired length. Important: the outer walls of the two sections must overlap a min of 2" to ensure a proper connection. When at the correct length, secure the two sections

together with (4) sheet metal screws provided.

4. Twist lock the Adjustable Length into the DuraTech chimney system. The Adjustable Length is not intended to support chimney either above or below. If the Adjustable Length is installed in a system with more than 4-ft of chimney above or below it, install a supporting component (Elbow Strap, Tee Support, etc) immediately above/below the Adjustable Length to carry the additional weight of the chimney.

CHIMNEY MAINTENANCE

1. Creosote and Soot: When wood is burned slowly, it produces tar and other organic vapors, which combine with expelled moisture to produce creosote. The creosote vapors condense in the relatively cool chimney flue of a slow-burning fire. As a result, creosote residue accumulates on the flue lining. When ignited, this creosote makes an extremely hot fire.

2. Access: Chimneys must be installed so that access is provided for inspection and cleaning.

3. When to Clean: The chimney should be inspected at least once every month during the heating season to determine if creosote or soot has built up. Check spark arrestor screens at least every 2 to 4 weeks. If creosote or soot has accumulated, it should be cleaned or replaced to reduce the risk of chimney fire.

4. How to Clean: Have your chimney cleaned by a Certified Chimney Sweep if you have doubts about your ability to clean it. Use a plastic, wood, or steel brush. Do not use a brush that will scratch the stainless steel liner of your chimney. Scrub the spark arrestor with a wire brush. To remove the Chimney Cap for cleaning unscrew the four (4) screws that attach the cap's support legs to the cap base. The Tee Cleanout Cap can be removed by turning counter-clockwise. Be sure to replace Tee Cleanout Cap when you are finished cleaning the chimney.

5. Coal: Warning: Coal with a high sulfur content

can lead to premature failure of the chimney. To reduce corrosion, clean the chimney thoroughly within 48 hours of shutting down the stove for the season. An annual inspection is required.

6. Chemical Cleaners: Use chemical cleaners only as a last resort, and use only those which the manufacturer specifically warrants as being noncorrosive to the chimney liner. DuraVent will assume no liability for damage resulting from the use of chemical cleaners.

7. In Case of Fire: If a flue fire occurs, close all appliance air inlets, and call your Fire Department. Do not use the chimney again, until it has been inspected for possible damage.

8. Painting: You can coat all exterior metal parts, with the exception of the Chimney Cap, with high temperature, rust proof paint. Wash the metal with a vinegar and water solution before painting. Painting the chimney will help to increase chimney life.

9. Creosote Formation: DuraVent assumes no liability for any structural damage or roof contamination as the result of creosote formation. It is the owner's responsibility to comply with inspection and cleaning requirements.

THIS PAGE IS INTENTIONALLY LEFT BLANK

THIS PAGE IS INTENTIONALLY LEFT BLANK

THIS PAGE IS INTENTIONALLY LEFT BLANK

DURAVENT LIMITED LIFETIME WARRANTY

DuraVent, Inc. provides this limited lifetime warranty for all of its products with the exception of Ventinox® (lifetime), and PolyPro® (ten years). Subject to the limitations set forth below, DuraVent warrants that its products will be free from defects in material or manufacturing, if properly installed, maintained and used. DuraVent products are fully warranted if installed only by a professional installer. This Warranty is transferable from the original homeowner to the buyer of the home. This warranty does not cover normal wear and tear, smoke damage or damage caused by chimney fires, acts of God, or any product that was: (1) purchased other than from an authorized DuraVent dealer, retailer or distributor; (2) modified or altered; (3) improperly serviced, inspected or cleaned; or (4) subject to negligence or any use not in accordance with the installation instructions included with the product as determined by DuraVent. Installation instructions are available online at www.duravent.com under Support/Literature and through our Customer Service Department 800-835-4429 or customerservice@duravent.com. This limited lifetime warranty applies only to parts manufactured by DuraVent.

DuraVent provides the following warranties for its products: One Hundred Percent (100%) MSRP 15 years from the date of purchase, and Fifty Percent (50%) thereafter, except for the following limitations on: all Termination Caps and DuraBlack® are warranted at One Hundred Percent (100%) for five years.

All warranty obligations of DuraVent shall be limited to repair or replacement of the defective product pursuant to the terms and conditions applicable to each product line. These remedies shall constitute DuraVent's sole obligation and sole remedy under this warranty. This warranty provides no cash surrender value. The terms and conditions of this warranty may not be modified, altered or waived by any action, inaction or representation, whether oral or in writing, except upon the express, written authority of an executive officer of DuraVent.

Corn, bio-fuels, driftwood or other wood containing salt, preservative-treated lumber, plastic and household trash or garbage, or wood pellets containing such materials must not be burned in the appliance or fireplace. In case of a chimney fire, the chimney must be inspected and approved by a certified Chimney Sweep before reuse. After each annual inspection, maintenance, and cleaning, the certified Chimney Sweep must fill out and date the appropriate section of the warranty card provided with the chimney liner.

LIMITATIONS ON INTERNET SALES: Notwithstanding any other terms or conditions of this Limited Lifetime Warranty, DuraVent provides no warranty for the following specific products if such products are not installed by a qualified professional installer: DuraTech®, DuraPlus HTC®, DuraTech Premium, DuraChimney® II, PelletVent Pro®, DirectVent Pro®, FasNSeal®, FasNSeal® W2, FasNSeal® Flex, and PolyPro®, and DuraVent's relining products including DuraLiner®, DuraFlex® (SW, Pro, 316, 304), and Ventinox®. For purposes of this warranty, a trained professional installer is defined as one of the following: licensed contractors with prior chimney installation experience, CSIA Certified Chimney Sweeps, NFI Certified Specialists, or WETT Certified Professionals.

DuraVent must be notified and given the opportunity to inspect defective product prior to replacement under the terms of this limited lifetime warranty. All warranty claims must be submitted with proof of purchase. Labor and installation costs are not covered under this warranty. To obtain warranty service contact: DuraVent Warranty Service, 877 Cotting Ct., Vacaville CA 95688, or call 800-835-4429.

WHERE LAWFUL, DURAVENT DISCLAIMS ALL OTHER WARRANTIES, INCLUDING BUT NOT LIMITED TO IMPLIED WARRANTIES OF MERCHANTABILITY AND FITNESS FOR A PARTICULAR PURPOSE. IN NO EVENT WILL DURAVENT BE LIABLE FOR INCIDENTAL, CONSEQUENTIAL, PUNITIVE OR SPECIAL DAMAGES OR DIRECT OR INDIRECT LOSS OF ANY KIND, INCLUDING BUT NOT LIMITED TO PROPERTY DAMAGE AND PERSONAL INJURY. DURAVENT'S ENTIRE LIABILITY IS LIMITED TO THE PURCHASE PRICE OF THIS PRODUCT. SOME STATES DO NOT ALLOW LIMITATIONS ON IMPLIED WARRANTIES, OR THE EXCLUSION OR LIMITATION OF INCIDENTAL OR CONSEQUENTIAL DAMAGES, SO THE ABOVE LIMITATIONS AND EXCLUSIONS MAY NOT APPLY TO YOU. THIS LIMITED WARRANTY GIVES YOU SPECIFIC LEGAL RIGHTS, AND YOU MAY ALSO HAVE OTHER RIGHTS THAT VARY FROM STATE TO STATE.

For the most up-to-date installation instructions, see www.duravent.com

REV 3.22.2012

Manufactured in Vacaville CA and Albany NY

DuraVent

Customer Service Support: 800-835-4429 • 707-446-4740 FAX • www.duravent.com

DuraTech is a registered trademark of DuraVent, Inc.
All rights reserved. Made in the USA. ©2012, 2017

L150-Rev.2_820019294_Install Instructions_DuraTech_06-28-21_V3