



# MHP

## OUTDOOR GRILLS

### Infra-Roast Rotisserie Burner Installation Instructions

(Grill Models: WNK, WRG, TJK, TRG, and THRG Series)

**Congratulations on your new purchase. We wish you many enjoyable and memorable cookouts.**

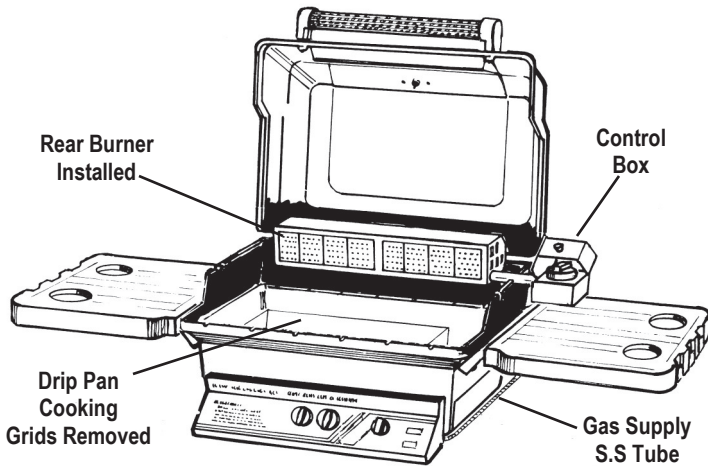

**NOTE:** The Infra-Roast Burner System RRB II is available for both free standing and built-in grills (models above). The correct part number for free standing grills is **GRRB2** and fits both Nu-Stone and Fold Down Stainless Steel Shelf Models. **GGBIRRB** is the correct part number for Built-In Models. You must specify Natural or Propane as there is a difference in Orifice size.

It is very important that you have the correct burner to match the gas being used.

When the rotisserie back burner is being used, **DO NOT USE THE INTERIOR BURNERS AT THE SAME TIME.** It would create too much heat and spoil the food on the rotisserie, and it could damage the grill.

Before starting the installation, turn the gas off at its source; tank or hose or pipe valve, not just at the front control panel valve. Please read these instructions completely. The MHP Dealer or the factory can answer any questions you may have.

**UNPACK ALL COMPONENTS AND MATCH THEM WITH THE PARTS DESCRIPTIONS ON RIGHT. CONTACT YOUR DEALER IF ANY THING IS MISSING.**

- 1. Main Grill Replacement Control Valve and Manifold (Factory Assembled)
- 2. Stainless Steel Burner Box
- 3. 8 Ceramic Tiles (not assembled)
- 4. Burner Tube (Venturi)
- 5. End Cap
- 6. Control Valve— Infra-Roast Burner
- 7. Control Valve Box
- 8. Valve/Box Mounting Bracket
- 9. Control Valve Knob
- 10. 1/4" Flare Flexible Stainless Steel Tubing
- 11. Drill Hole Template
- 12. Drill Bit
- 13. Two—10-24 x 1 3/4" Bolts
- 14. Two—10-24 Kep Nuts

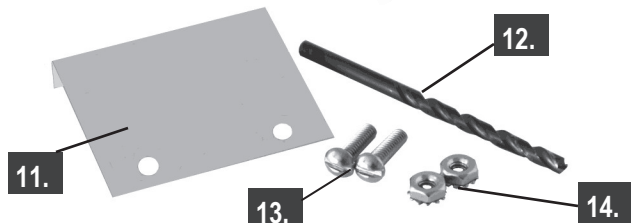
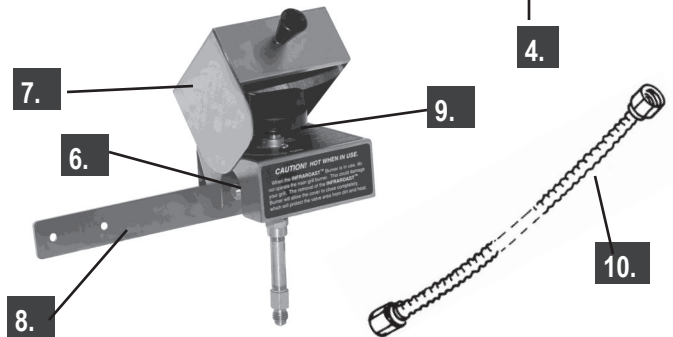
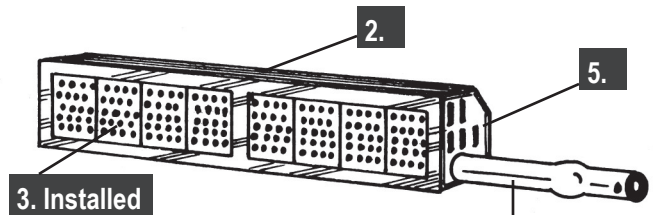
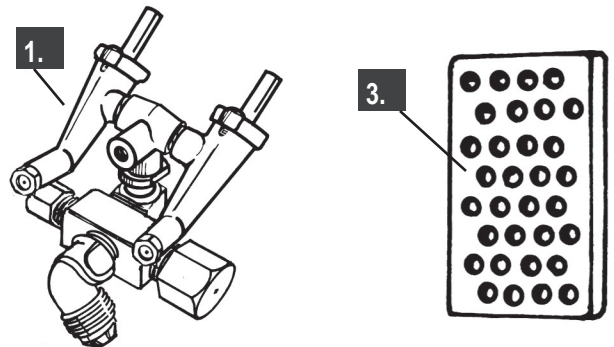

**Tools Required:** Two wrenches capable of adjustment to cover a range from 1/2" to 1 1/16"; a flat blade screwdriver, a pair of pliers and an electric drill. **No pipe sealant is necessary on flare fittings.**

The first step in the installation is to remove the grill's front control panel so you can gain easy access to the main grill control valve and replace it with the new valve/manifold combination.

**Make sure the gas is "OFF" at the main source.** Using two wrenches, as illustrated, disconnect the gas supply line from the Main Control Valve under the center of the Control Panel. It is easier to do it now while the valve is sturdily mounted.

Remove the Cooking Grids, rocks and rock grate from the grill to get at the two 1/4-20 nuts that hold the Control Panel to the grill casting. Remove these nuts using a 7/16" wrench. Pull the panel carefully away from the grill and if you haven't already, disconnect the Ignitor wire from the Ignitor.

The Main Control Valve is held on a bracket with a single 1/20 bolt with a 7/16" hex head nut. Remove the bolt and replace this "OLD" valve with the new one. Tighten securely. Recycle the old brass valve.

After reattaching the control panel with the two nuts previously removed, reinstall the main fuel hose, as shown, using two wrenches. Replace the Ignitor wire.

**DO NOT TURN ON THE FUEL SUPPLY YET.**

**VERY IMPORTANT NOTE:**

As illustrated at right. The main fuel supply from the tank, hose or pipe connects to the 3/8" flare fitting that has no cap on it (No. 1). The capped 3/8" flare fitting (No. 2) is for a future connection to a side burner. Do not loosen or remove this cap unless it will be used for the side burner.

The capped 1/4" flare fitting (No. 3) will be used to supply gas to the Infra-Roast burner which you are installing now. Two wrenches should be used to remove the cap so that the fitting will not be loosened from the manifold.

Next, drill the two control box mounting holes on the back side of the bottom grill casting using the supplied drill bit and metal template. The grill lid may be removed for easier access during this operation.

Standing behind the grill, position the template to rest on top of the bottom casting lip and slip it to the right until it contacts the hinge. Hold it firmly in this position and using the supplied drill bit spot the holes enough to break the paint surface to use as drill spot and indicator.

Remove the metal template and finish drilling the holes completely through the casting.

Now you can bolt the control bracket to the casting using the supplied bolts and kep nuts.

**NOTE:** Built-In Grill Models **Do Not** need the casting drilled. The control box and bracket simply bolt down to the two through mounting holes on the stainless steel sleeve behind the right corner of the grill.

**DISCONNECT GAS SUPPLY LINE**

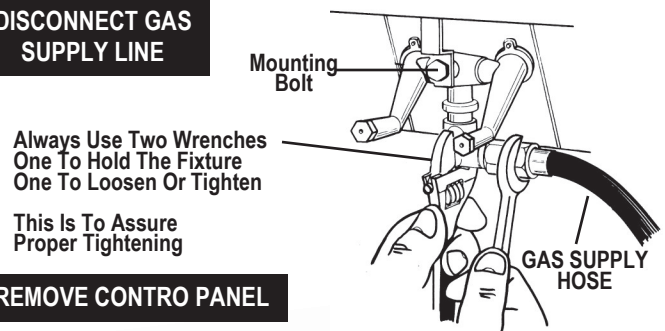

Always Use Two Wrenches  
One To Hold The Fixture  
One To Loosen Or Tighten

This Is To Assure  
Proper Tightening

**REMOVE CONTROL PANEL**

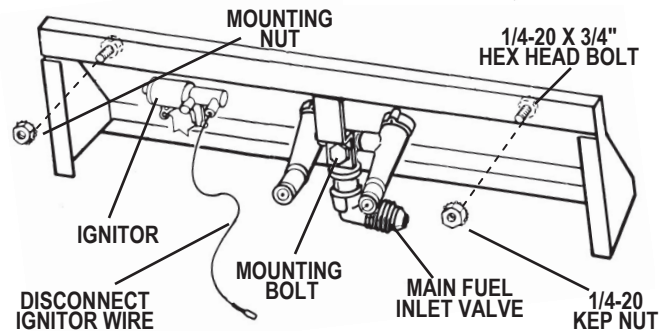

**NEW VALVE ASSEMBLY**

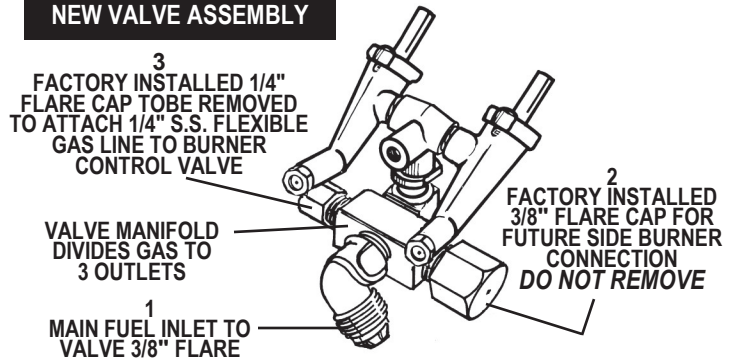

**MOUNTING CONTROL BOX**

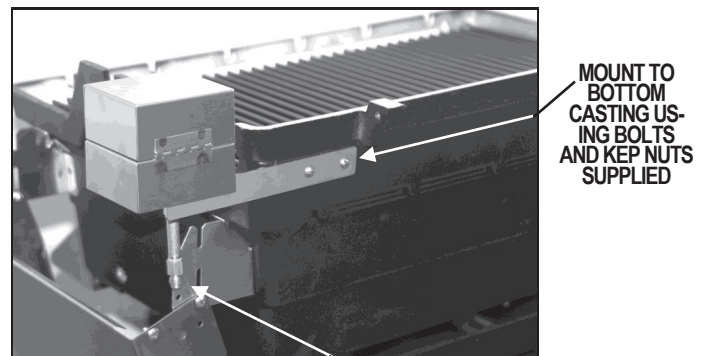
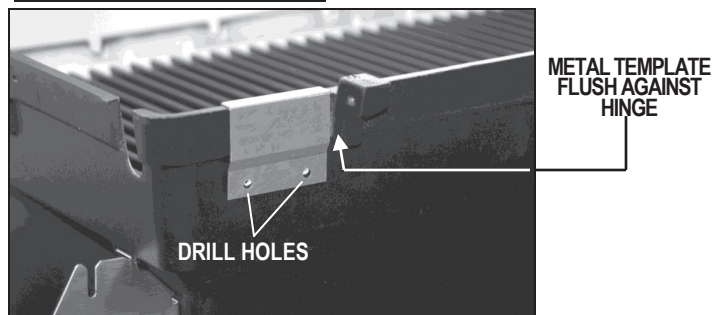

1/4" FLARE CONNECTION  
FOR S. S. GAS LINE

## ASSEMBLE THE BURNER

Place Infra-Roast Ceramic tiles into the burner. Remove the two screws that hold the end cap in place. With the end cap removed, simply slide the eight tiles into the preformed channel.

**NOTE: The tiles have two faces (a front and a back). On one face (the back) there are four protruding dimples. Put these dimples on the inside of the burner, keep the smooth side out.** Reinstall the end cap.

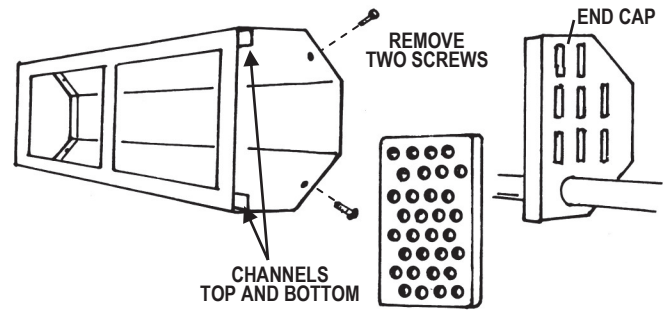

## MOUNT THE BURNER ON THE GRILL

If not already done, remove the grill Warming Rack. This device would be in the way and cannot be used when the Infra-Roast Burner is being used.

The Burner gas venturi tube is placed into the "U" shaped notch in the grill casting at the same time that the end of the tube is slipped over the gas valve orifice in the Control Box. The Burner has two hanging brackets on the back surface, which must be pressed firmly over the grill edge. Make sure that the Burner appears level on the grill back edge or burning characteristics could be affected. Also, to the best of your ability, see that the burner gas valve orifice is inside the burner venturi tube.

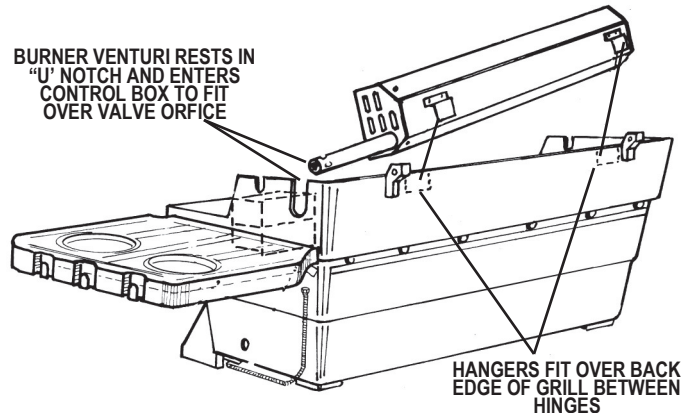

The Cooking Grid should be removed during the use of a Rotisserie to allow room for rotating foods to clear interior grill parts. A shallow pan containing some water may be placed on top of the rock grate to catch any dripping fat and keep it off the "H" shaped burner (the "H" burner is not used at the same time the rotisserie burner is being used, but grease may plug "H" burner holes and affect regular cooking use).

Finally, the 1/4" flexible stainless steel gas supply tubing is connected to the right side of the main control valve/manifold after removing the small flare end cap. **(Do not remove the 3/8" flare cap unless you are also installing a side burner). USE TWO WRENCHES TO PREVENT LOOSENING THE FITTING WHICH GOES INTO THE MANIFOLD.** Lead the tubing along the contour of the grill side and up to the bottom of the burner valve. Again, using two wrenches, attach the flex tube to the valve. **No pipe sealant is used.** The tubing bends very easily and will not kink as it is "pressed" into position.

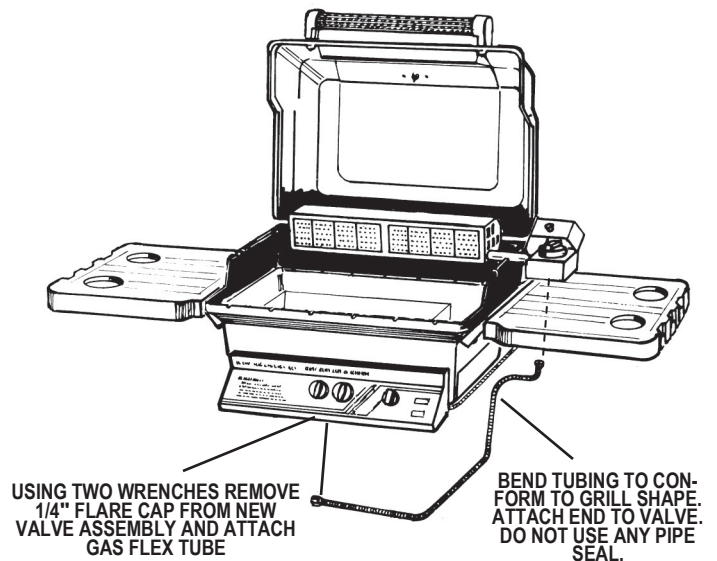

## LIGHTING THE INFRA-ROAST BURNER

The Infra-Roast unit is designed to be used alone inside the grill. **DO NOT** use it along with the "H" burner in the bottom of the grill, that burner stays "OFF". The Infra-Roast burner will heat the entire grill interior (and exterior surfaces) by itself.

Depress the burner control knob and turn it counterclockwise to the "HIGH" position. Immediately light the burner at the far right lower corner using a long match or hand held butane lighter. If the burner does not light, turn valve "OFF" and wait a minute for the gas to clear and try again. It is possible for the gas to take an extra moment to get to the burner, especially when newly installed. The burner is designed to be used on "HIGH" with the grill lid closed. Preheat for about 10 minutes.

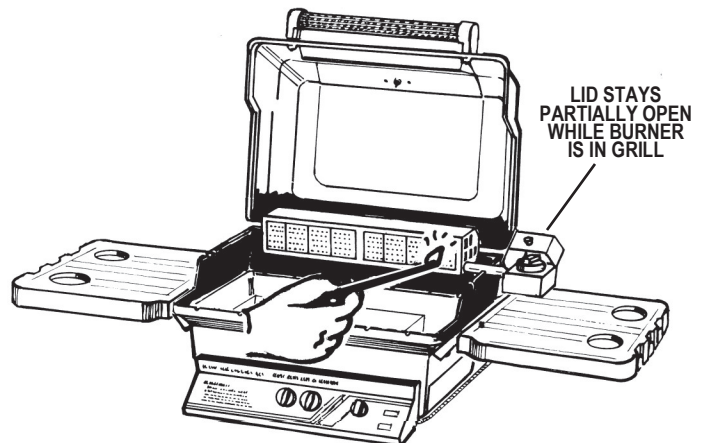

## PERFORMANCE AND MAINTENANCE TIPS

Your Infra-Roast Burner is constructed of high quality 300 series stainless steel for long lasting performance. You will notice a discoloration of the metal immediately during its first use. **THIS IS NORMAL.** The high cooking temperatures will cause the discoloration.

Various odorants and minerals are present in both natural gas and propane for your protection. During the combustion process some residue may form on the face of the burner. This can be wiped off before the next cooking **while the burner is cold.**

The Infra-Roast Burner is designed to cook with the grill lid completely closed and with the heat control on "HIGH". Outside temperatures and certain windy conditions can greatly affect cooking times so experimentation is the key to beautifully prepared roasts and fowl.

If you experience a burner blowout on an excessively windy day, turn the gas off and wait a few minutes for the gas to clear and relight the burner. The grill lid may be propped open an inch or so to relieve internal pressures caused by the wind or you may also reposition the grill (if on portable cart) for better wind protection.

**During operation and after shutdown, the burner and related components are EXTREMELY HOT!  
BE CAREFUL!**

## COOKING TIPS

Using the back Infra-Roast Burner is a fun and exciting method of food preparation. With some practice you MHP Intra-Roast System will provide flavor and convenience not possible with conventional gas grill cooking.

We recommend a shallow baking pan or shaped aluminum foil to collect the "drizzles." Place the pan on top of the grill rock directly beneath the food on the spit. Keep 1/2" to 1" of water in the pan to provide moisture, collect the juices for gravy, or just to make the pan easier to clean. Because the main grill burner is not used, collecting the "drizzles" also prevents grease from staining the grill rocks—and there will be no flare-ups.

One of the major advantages of cooking on a spit with the food rotating is that flavor can be added by basting. Even a fine rib roast, although excellent basted with its own juices, can have the flavor varied in a number of interesting ways.

A basting sauce may be applied to the food before or during the cooking. No single baste sauce is perfect for all the different foods you can cook, so experiment. A good baste need not be complicated, the most famous are usually the simplest. But try to use the best ingredients: fresh herbs, good sherry, vermouth, beer and so on.

A good basting sauce needs to be a thick liquid—easy to apply, yet not so liquid that it runs off as the food rotates. The sauce base may be soy sauce (taking the place of salt), vinegar, soup stock, or water with a dissolved bouillon cube. To thicken, and depending on the fatness of the meat or fish, it should also contain some fat: butter, olive oil, bacon grease or the drippings of the food being cooked.

In addition, you'll want seasonings. Best are fresh herbs; next best, dried herbs. The need for salt or pepper varies. If you apply salt to the outside of a roast it tends to draw moisture from the meat. Save the salt for the table. If you cook slow enough, you'll need very little of either anyway. A meat that is still moist when cooked contains so much more flavor than when dried out.

Here are a few hints that will make a difference:

1. Have the meat, fish or fowl at room temperature before putting it on the spit or in a spit basket.
2. Allow 10 to 15 minutes "coasting" time. Turn the Infra-Roast Burner off and let the spit keep rotating.
3. Use a meat thermometer to determine if cooked adequately.

**Modern  
Home Products**  
Corporation

150 South Ram Road, Antioch, Illinois 60002

Phone: 1-888-647-4745 • 847-395-6556

Fax: 1-800-637-2918 • 847-395-9121

E-Mail: [customerservice@mhpgrills.com](mailto:customerservice@mhpgrills.com)

Web Site: [www.mhpgrills.com](http://www.mhpgrills.com)

## Other Quality Products From Modern Home Products



The Grill That  
Cooks It All



First in Grill  
Replacement Parts

ProFire® Grills  
Perfection by Design

Stainless Steel Grills

Everglow

Outdoor Lighting