



AMD Direct

**24SA & 24G REFRIGERATOR
USER MANUAL**



AMD DIRECT REFRIGERATOR

INSTALLATION INSTRUCTIONS & OWNERS MANUAL

NAME: 24" 5.1C OUTDOOR RATED REFRIGERATOR
24" 5.1C OUTDOOR RATED REFRIGERATOR W/ GLASS DOOR

PART #: RFR-24SA / RFR-24G

THANK YOU

Thank you for your purchase. We'd like to welcome you to the AMD Direct family of luxury outdoor kitchen products and look forward to being a part of your home for years to come. As a family business with over 20 years of industry experience, we aim to deliver exceptional quality and personal service. Welcome to the AMD Direct family and we hope you love your new refrigerator!



For warranty information and to register your refrigerator visit, www.amddirect.com/register

To view on your phone, scan the QR code on your camera app. camera app. (For Android devices, use Google Lens)

INSTALLER

Please leave this manual for the owner

Serial Number: _____

Model: _____

Date of Purchase: _____

Place of Purchase: _____

SAFETY AND INSTALLATION INSTRUCTIONS

WARNING

Before the appliance is used, it must be properly positioned and installed as described in this manual, so read the manual carefully. To reduce the risk of fire, electrical shock or injury when using the appliance, follow basic precautions, including the following:

- Plug into a grounded 3-prong outlet, do not remove prong, do not use an adapter and do not use an extension cord.
- Replace all panels before operating.
- It is recommended that a separate circuit serving only your appliance be provided. Use receptacles that cannot be turned off by a switch or pull chain.
- Never clean appliance parts with flammable fluids. These fumes can create a fire hazard or explosion.
- Do not store or use gasoline or other flammable vapors and liquids in the vicinity of this or any other appliance. The fumes can create a fire hazard or explosion.
- Do not connect or disconnect the electric plug when your hands are wet.
- Unplug the appliance or disconnect power before cleaning or servicing. Failure to do so can result in electrical shock or death.
- Do not attempt to repair or replace any part or your appliance unless it is specifically recommended in this manual. All other servicing should be referred to a qualified technician.

WARNING

RISK OF CHILD ENTRAPMENT

1. Child entrapment and suffocation are not problems of the past. Junked or abandoned appliances are still dangerous, even if they will “just sit for a few days.”

WARNING

1. Stainless steel exposed to chlorine gas and moisture from areas such as spas or swimming pools may experience discoloration. Discoloration from chlorine gas is normal.
2. NEVER USE CHLORIDE TO CLEAN STAINLESS STEEL.

POWER FAILURE

Most power failures are corrected within a few hours and should not affect the temperature of the appliance if the number of times the drawer is opened is minimized. If the power is going to be off for a longer period of time, take proper steps to protect the contents.

VACATION TIME

Short Vacations: Leave the appliance operating during vacations of less than three weeks.

Long Vacations: If the appliance will not be used for several months, remove all items and turn off the appliance. Clean and dry the interior thoroughly. To prevent odor and mold growth, leave the door open slightly, blocking it open if necessary.

MOVING YOUR APPLIANCE

- Remove all items.
- Securely tape down all loose items inside your appliance.
- Turn the adjustable legs up to the base to avoid damage.
- Tape the door shut.
- Be sure the appliance stays secure in the upright position during transportation. Also protect the outside of the appliance with a blanket or similar item.

GENERAL SAFETY REQUIREMENTS

ENERGY SAVING TIPS

- The appliance should be located in the coolest area of the room or outdoor location, away from heat-producing appliances and out of direct sunlight.
- Ensure that the unit is adequately ventilated. Never cover air vents.
- Do not keep the door open any longer than necessary.
- Let hot foods cool to room temperature before placing in the unit. Overloading the unit forces the compressor to run longer.
- Be sure to wrap foods properly and wipe containers dry when placing them in the unit. This cuts down on frost build up in side the unit.
- Unit door should not be lined with aluminum foil, wax paper or paper toweling.
- Liners interfere with cold air circulation, making the unit less efficient.
- Organized and labeled stored items reduce door openings and extended searches.
- Remove as many items as needed at one time and close the door as soon as possible.



FOLLOW WARNING CALLOUTS BELOW ONLY WHEN APPLICABLE TO YOUR MODEL

- Use two or more people to move and install the appliance. Failure to do so can result in back or other injury.
- To ensure proper ventilation for your appliance, the front of the unit must be completely unobstructed.
- Choose a well-ventilated area with temperatures above 50°F (10°C) and below 109.4°F (43°C).
- The appliance should not be located next to ovens, grills, or other sources of high heat.
- The appliance must be installed with all electrical, water, and drain connections in accordance with state and local codes. A standard electrical supply (115 V AC only, 60HZ), properly grounded in accordance with the National Electrical Code and local codes and ordinances is required.
- Do not kink or pinch the power supply cord of the appliance.
- The size of the fuse (or circuit breaker) should be 1.3 amperes.
- It is important that the appliance be leveled in order to work properly. You may need to make several adjustments to level it.
- All installations must be in accordance with local plumbing code requirements.
- Never allow children to operate, play with or crawl inside the appliance.
- Do not use solvent-based cleaning agents or abrasives on the interior. These cleaners may damage or discolor the interior.
- Use this appliance only for its intended purposes as described in this instruction manual.
- Keep fingers out of the “pinch point” areas. Clearances between the door and cabinet are necessarily small. Be careful closing door when children are in the area.





24" REFRIGERATOR USER MANUAL

TABLE OF CONTENTS

BEFORE OPERATING	1
TROUBLESHOOTING	2
OPERATING YOUR APPLIANCE	3
INSTALLATION	4
WARRANTY	6
LINE DRAWINGS	7

BEFORE OPERATING

Shipment Arriving Damaged:

VISIBLE DAMAGE

If your shipment arrives with visible damage to the box/carton, be sure the damage is noted on the bill of freight or express receipt and signed by the person making the delivery. File a claim for damages immediately, regardless of the extent of damage.

CONCEALED DAMAGE

If damages are unnoticed until the kegerator is unpacked, notify the transportation company or carrier immediately and file a concealed damage claim with them. This should be done within (5) days of the delivery date. Be sure to hold on to the box/carton for inspection. We cannot assume responsibility for damage or loss incurred in transit.

Important Notes:

CONSTRUCTION NOTES

Keep all stainless steel products away from construction zones. Construction debris such as (but not limited to) stone dust, stucco, and lime dust could damage or permanently discolor stainless steel products. Keep all caustic chemicals including chlorine and pool cleaning products away from stainless steel at all times.



ELECTRICAL PARTS & COMPONENTS

Disconnect all power supplies and batteries before servicing.

INTERIOR LIGHT

This unit is equipped with an interior LED light which will be turned ON when the door is open and the interior fan is stopped at the same time. You can press  to manually turn on or turn off the light.

DEFROSTING

The unit defrosts automatically in normal operating conditions. The evaporator behind the rear wall of the unit defrosts automatically. The condensation collects in the drainage channel behind the rear wall of the unit and flows through the drainage hole into the drop tray by the compressor where it evaporates. However, frost may accumulate on the evaporator if the unit is repeatedly opened in a high heat or high humidity location. If this frost pattern does not clear within 24 hours, your unit will require manual defrosting.

Press  and hold for 6 seconds to defrost the unit. To stop defrosting, repeat the same interaction.

TEMPERATURE ALARM

An audible alarm sounds if the storage temperature is not cold enough. The temperature display flashes at the same time.

The cause of the temperature being too high may be:

- Warm fresh food placed inside.
- Too much warm ambient air flow when rearranging and removing stored items.
- Power failure for some time.
- The appliance is faulty.

The audible alarm is automatically silenced and the temperature display stops flashing when the temperature is sufficiently cold again.

CLEANING AND MAINTENANCE

Periodic cleaning and proper maintenance will ensure efficiency, top performance and long life. The maintenance intervals listed are based on normal conditions. You may want to shorten the intervals if you have pets or other special considerations.

Exterior cleaning for your stainless steel model:

- Your stainless steel model may discolor when exposed to chlorine gas, pool chemicals, salt water or cleaners with bleach.
- Keep your stainless unit looking new by cleaning with a high quality, all-in-one stainless steel cleaner/polish on a monthly basis. Frequent cleaning will remove surface contamination that could lead to rust. Some installations will require cleaning on a weekly basis.
- DO NOT CLEAN WITH STEEL WOOL PADS.
- DO NOT USE CLEANERS THAT ARE NOT SPECIFICALLY INTENDED FOR STAINLESS STEEL (This includes glass, tile and counter cleaners).
- If any surface discolor or rusting appears, clean it quickly with Bon-Ami or Barkeepers Friend Cleanser and a non-abrasive cloth. Always clean in the direction of the grain. Always finish this process with a high quality, all in one stainless cleaner/polish to prevent further problems.
- USE OF ABRASIVE PADS SUCH AS SCOTCHBRITE WILL CAUSE THE GRAINING IN THE STAINLESS TO BECOME BLURRED.
- Rust that is allowed to linger can penetrate into the surface of the stainless steel and become impossible to remove.

TROUBLESHOOTING

Many common problems can be solved easily, saving you the time spent communicating with customer service. Try the suggestions below to see if the issue has a simple solution.

PROBLEM	POSSIBLE CAUSE	REMEDY
Appliance does not operate.	Appliance is not connected to a power supply. The appliance is turned off. Tripped circuit breaker or a blown a fuse.	Connect the appliance. Switch on the appliance. Switch on the circuit breaker or replace fuse.
Appliance is not cold enough.	The temperature is not set correctly. Temperature could require a lower temperature setting. The drawer was not closed completely. Drawer is not hermetically sealed. The condenser is too dirty. The ventilation opening is blocked or too dusty.	Check the set temperature. Set a lower temperature. Do not open the drawer more often than necessary. Close drawer properly. Check the drawer seal and clean/replace. Clean the condenser when necessary. Clear the obstructions, clean the dust.
Appliance turns itself on and off frequently.	The room temperature is higher than average. A large amount of food has been added to the unit. The drawer is open too often. The drawer is not closed completely. The drawer gasket does not seal properly.	Put the appliance in a cooler place. Leave the appliance to work for a while until the set temperature has been reached. Do not open more than necessary. Close drawer properly. Check the drawer seal and clean/replace.
The light does not work.	Appliance is not connected to a power supply. Tripped circuit break or blown a fuse. The light was switched off on the control panel.	Connect the appliance. Switch on circuit breaker or replace fuse. Switch on the light.
Vibrations.	The appliance is not properly leveled.	Level the appliance with the adjustable feet.
The appliance seems to make too much noise.	The rattling may come from the flow of the refrigerant, which is normal. As each cycle ends, you may hear gurgling sounds caused by the flow of refrigerant in your appliance. If the temperature fluctuations occur, the contraction and expansion of the inner walls may cause popping and cracking noises. The appliance is not properly level.	Level the appliance with the adjustable feet.
The drawer will not close properly.	The appliance is not properly level. The drawer was reversed and not properly installed. The gasket is dirty.	Level the appliance with the adjustable feet. Check the drawer hinge and reassemble correctly. Clean the drawer gasket.
The alarm sounds and the temperature display flashes.	Has the appliance drawer been open for longer than 60 seconds? If not, then the temperature has risen higher or fallen lower than the temperature that has been set. This could be due to: The appliance drawers being opened too often. The ventilation opening being covered or too dusty. A lengthy interruption in the power supply. A large amount of food has been added to the unit.	If yes, close the drawer. Do not open the drawer more often than necessary. Clear the obstructions and clean the dust. Leave the appliance to work for a while until the set temperature has been reached.

OPERATING YOUR APPLIANCE

It is recommended that you install the appliance in a place where the ambient temperature is between 50°F and 109.4°F (10°C-43°C). If the ambient temperature is above or below recommended temperatures, the performance of the unit may be affected. For example, placing your unit in extremely cold or hot conditions may cause interior temperatures to fluctuate. The operating temperature range may not be reached.

CONTROL PANEL

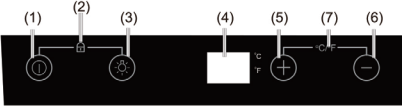

SECURITY AND STARTUP

1. To turn the appliance ON or OFF, press and hold the Power key for 5 seconds.
2. Press and hold simultaneously to Unlock and Lock the Control Panel.
3. Turns the Interior Light ON and OFF
4. Displays the Temperature

TEMPERATURE SETTINGS

5. Increase Set Temperature 1 °F with each push
6. Decrease Set Temperature 1 °F with each push
7. Press and hold simultaneously to alter the Temperature Display to Fahrenheit or Celsius

TEMPERATURE ALARM / DOOR ALARM

An audible alarm sounds if the storage temperature is not cold enough. The temperature display flashes at the same time.

The Cause of the temperature being too high may be:

- Warm fresh food was placed inside
- Too much warm ambient air flowed in when rearranging and removing stored items
- Power failure at the power source
- The appliance is faulty

The audible alarm is automatically silenced and the temperature display stops flashing when the temperature is sufficiently cold again.

If the door has been left open for more than 60 seconds, the alarm will sound.

Pressing any key once can switch off the audible alarm.

BEFORE USING YOUR APPLIANCE

Remove the exterior and interior packing.

Before connecting the appliance to the power source, let it stand upright for approximately 24 hours. This will reduce the possibility of a malfunction in the cooling system from handling during transportation.

Clean the interior surface with lukewarm water using a soft cloth.

Install the handle on the door if not already attached.

INSTALLATION OF YOUR APPLIANCE

Your outdoor refrigerator has been designed for both built-in and freestanding applications. When built-in, your refrigerator door does not require additional air space for top, side or rear. The front grille must not be obstructed.

NOTE:

It is recommended that you do not install the appliance near an oven, radiator or other heating source, as heat sources may increase electrical consumption. Do not install in a location where the temperature will fall below 50°F (10°C). For best performance, do not install the appliance behind a cabinet door or block the base grille. Plug the appliance into an exclusive properly grounded wall outlet.

SITE PREPARATION

1. Position the unit on a flat, level surface capable of supporting the entire weight of the unit. Remember the unit will be significantly heavier once it is fully loaded.
2. Connect the unit to a Ground Fault Interrupter (GFI).
3. The unit must be installed according to your local codes and ordinances.
4. **ELECTROCUTION HAZARD!**
 - Electrical Grounding Required - This appliance is equipped with a 3-prong (grounding) polarized plug for your protection against possible shock hazards.
 - NEVER remove the round grounding prong from the plug.
 - NEVER use a 2-prong grounding adapter.
 - NEVER use an extension cord to connect power to the unit.
 - Where a 2-prong wall receptacle is encountered or a longer power cord is required, contact a qualified electrician to have it replaced in accordance with applicable electrical codes.

INSTALLATION

LOCATION OF PARTS

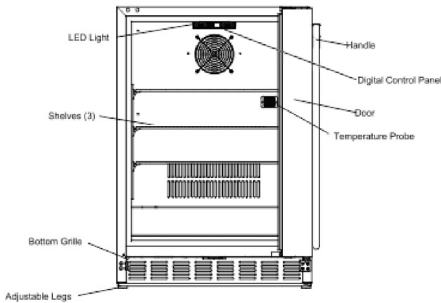

1. Position the unit to allow free air flow through the front grille.

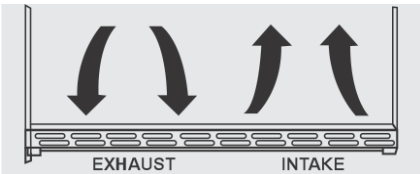

2. Wipe out inside of the unit with a damp cloth.

INSTALLING THE STAINLESS STEEL HANDLE

To install the handle, follow the instructions below.

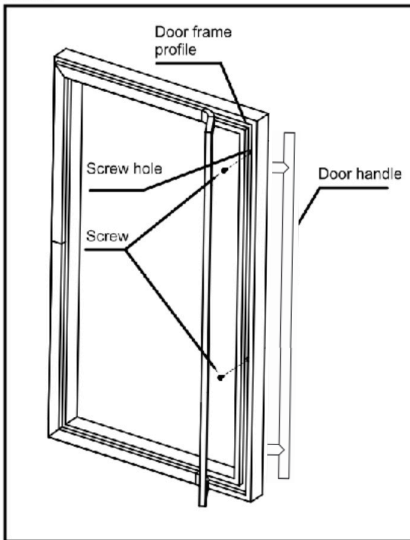

Remove the right side gasket.

Take out the screws from the bag in the cabinet. Put the screws in the holes where the handle is to be installed.

Align the handle with screws, tighten the screws using a screwdriver until the handle is both flush and secured tightly against the door side. (DO NOT overtighten as this may cause damage to the door surface).

LEVELING THE UNIT

Position the unit on a flat, level surface capable of supporting the entire weight of the unit when full. The unit contains four (4) adjustable leveling legs. Turn the legs clockwise to raise and counterclockwise to lower.

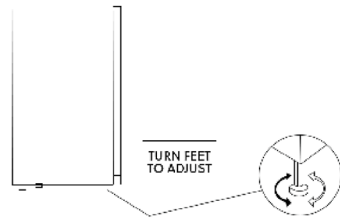

ELECTRICAL CONNECTION

Put the screws on top of the door where the handle is to be installed. Align the handle with screws, tighten the screws using the screwdrivers.

⚠ WARNING ⚠

Improper use of the grounded plug can result in the risk of electrical shock. If the power cord is damaged, have it replaced by a qualified or an authorized service dealer.

INSTALLATION

ELECTRICAL CONNECTION CONTINUED

This appliance should be properly grounded for your safety. The power cord of this appliance is equipped with a 3-prong plug which mates with a standard 3-prong wall outlet to minimize the possibility of electrical shock.

Do not under any circumstance cut or remove the 3rd (ground) prong from the power cord supplied. For personal safety, this appliance must be properly grounded. Any questions concerning power and/or grounding should be directed toward a certified electrician or an authorized service center.

The appliance requires a standard 115/120 Volt AC-60HZ three-prong grounded electrical outlet. Have the wall outlet and circuit checked by a qualified electrician to make sure they outlet is properly grounded. When a standard 2-prong wall outlet is encountered, it is your responsibility and obligation to have it replaced with a properly grounded 3-prong wall outlet.

To prevent accidental injury, the cord should be secured behind the appliance and not left exposed or dangling.

The appliance should always be plugged into its own individual electrical outlet which has a voltage rating that matches the rating label on the appliance. This provides the best performance and also prevents overloading house wiring circuits that could cause a fire hazard from over heating. Never unplug the appliance by pulling on the power cord. Always grip the plug firmly and pull straight out from the receptacle. Repair or replace immediately all power cords that have become frayed or otherwise damaged. Do not use a cord that shows cracks or abrasion damage along its length or at either end. When moving the appliance, be careful not to damage the power cord.

EXTENSION CORD

Because of potential safety hazards under certain conditions, it is strongly recommended that you do not use an extension cord with this appliance. However, if you must use an extension cord it is absolutely necessary that it be a UL/CUL-Listed, 3-wire grounding type appliance extension cord having a ground type plug and outlet and that the electrical rating of the cord be 115 volts and at least 1.3 amperes.

LINE DRAWINGS

RFR-24SA

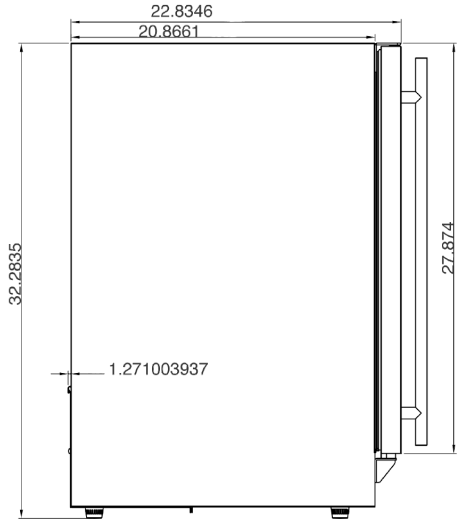
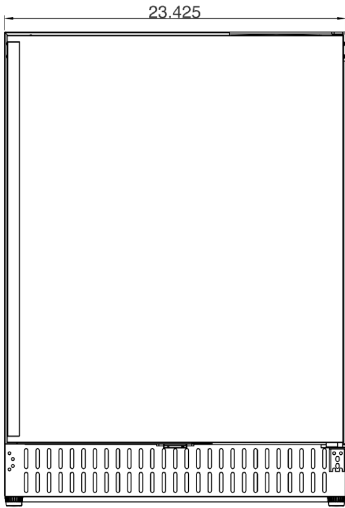

RFR-24G

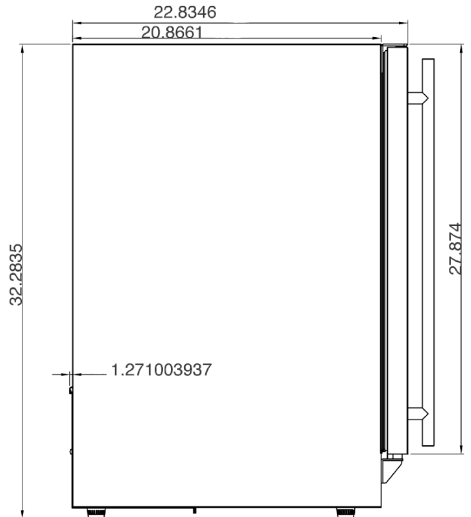
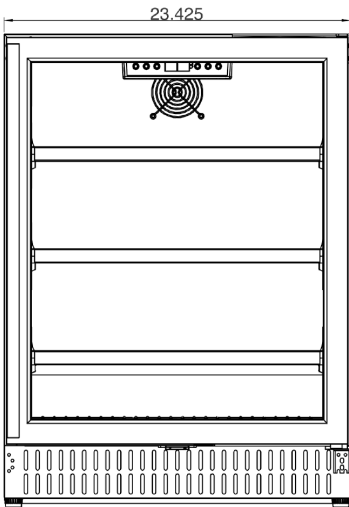

GOLD STANDARD WARRANTY

Your investment in AMD Direct products is backed by the strongest warranty in the industry. In addition to precision engineering and outstanding performance, AMD Direct products include our GOLD STANDARD LIFETIME WARRANTY with all replacement parts 100% non-prorated. Effective with purchases as of 3/1/23.

AMD Direct Warranty is valid for original purchaser at original site of delivery with proof of purchase and photo documentation only. Registration form must be submitted online within 30 days of the purchase date to validate the warranty. Warranty is void upon transfer of ownership. Warranty does not apply to products installed in any commercial, rental, or nonresidential application that have not maintained proper upkeep. Warranty covers replacement parts only. Manufacturer is not responsible for labor or labor-related costs. Warranty does not cover discoloration, surface rust, corrosion, or oxidation, which may occur due to harsh environments, chemicals, or overheating. Warranty will not apply for damage resulting from improper installations, abuse, extreme environments, grease fires, or misuse. Proof of regular and proper maintenance is required. Coastal, humid, and/or salt environments are subject to manufacturer review. All out-of-box claims must be made within 30 days of purchase and must be made prior to installation. Any product installed damaged will be considered damaged during installation and not covered under warranty. Warranty and registration forms are available at www.amddirect.com/register. Please be advised - all display models are sold "as is" and the warranty covers the following items only: main burners (Gold Standard Lifetime Warranty), grates (Gold Standard Lifetime Warranty), burner covers (Gold Standard Lifetime Warranty). All warranties are subject to the review and approval of the manufacturer.

14520 DELTA LANE SUITE 105,
HUNTINGTON BEACH, CA 92647

800.966.8126

AMDDIRECT.COM



AMD Direct 

CONTACT US

14520 Delta Ln,
Suite 105
Huntington Beach, CA 92647

AMDDirect.com

(800) 966-8126
M–F 8:30 am – 5:00 pm (PST)

VER.113023