

Please read and save these instructions. Read carefully before attempting to assemble, install, operate, or maintain the product described. Protect yourself and others by observing all safety information. Failure to comply with instructions could result in personal injury and / or property damage! Retain instructions for future reference.

KOLDWAVE

Portable Air Conditioners

Description

Thank you for selecting this Koldwave Portable Air Conditioner. Please read this manual before installing the 7KK14, 7KK17, or 7KK21 unit as it provides important information that should be followed during installation and maintenance. This will allow you to correctly set up your system for maximum safety and performance.

These units utilize a dedicated spot cooling thermostat that will provide you with spot cooling for large areas where cooling of an entire area is not practical or possible. These air conditioners can also be used in smaller areas for room cooling. Suitable applications include: a factory or workplace, industrial kitchen, computer room, emergency cooling, outdoor events, etc. A control panel with display provides ease of use and contains a self-diagnostic function. The display shows operating modes, room and set temperatures, and faults. If abnormal operation occurs, a visual display of the fault is shown. Caster wheels are included for easy portability.

If you experience a problem with your unit, please refer to the troubleshooting section of this manual to correct the problem (see page XX). If the problem is not corrected, please collect information so that the Technical Support personal can more effectively assist you. Technical Service can be reached by calling (413)564-5530 or emailing technicalservice@koldwave.com.



7KK14/7KK17/7KK21
Figure 1

Table of Contents

Specifications	3
Wiring Diagram (7KK14, 7KK21)	4
Wiring Diagram (7KK17)	5
General Safety Information	6
Unpacking	8
Assembly	9
Installation	10
Operation	11
Maintenance FILTER CLEANING	14
Maintenance (Continued)	15
SPRING REPLACEMENT	15
SELF-DIAGNOSTIC CODES	15
SELF-DIAGNOSTIC ALARM CODES	16
Troubleshooting chart	17
SHIPPING LIST	18
OBTAINING SERVICE	19
LIMITED PRODUCT WARRANTY	20

Specifications

Specifications	Unit	7KK14	7KK17	7KK21
Power Supply	V/Ph/Hz	115/1/60		230/1/60
Cooling Capacity	BTU/hr	13,200	16,800	21,200
Power Consumption	W	1058	1740	2200
Rated Current	A	9.2	15.8	10.9
Nema Plug		5-15P	5-20P	6-15P
Power Cord Gauge	AWG	14	12	14
Power Cord Length	ft.	10	6	10
Dimensions WxDxH	inch	20.5 x 27 x 41.1		
Weight (Net)	lbs.	174.1	178.6	187.6
Weight (Shipping)	lbs.	187.4	194	211
Number of Cool Air Outlets		2		
Condensate Tank	gal.	4		
Ambient Temperature Range	°F	64 ~ 113		
Setting Temperature (Room Cool Mode)	°F	64 ~ 86		
Setting Temperature (Spot Cool Mode)	°F	32 ~ 86		
Application Area (Room Cool Mode)	ft ²	355	430	538
Refrigerant Type		R-410A		
Refrigerant Amount	oz.	19.4	21.1	25
Indoor Air Flow (High)	CFM	405	470	560
Indoor Air Flow (Low)	CFM	345	400	465
Wheel Diameter	inch	3		
Hot Air Duct Diameter	inch	12		
Maximum Duct Length (Cold Air Supply)	ft.	30		
Maximum Duct Length (Hot Air Discharge)	ft.	50		
Safety Devices	Compressor overload protector, Anti-freezing thermister, Full drain tank switch, Automatic restart (Power interruption), Compressor time delay program, High pressure switch			
Features	Temperature control, Self-diagnostic function, Two speed fan, Optional drain pump kit, Washable filters, °F (°C) display, Off-timer			

Wiring Diagram

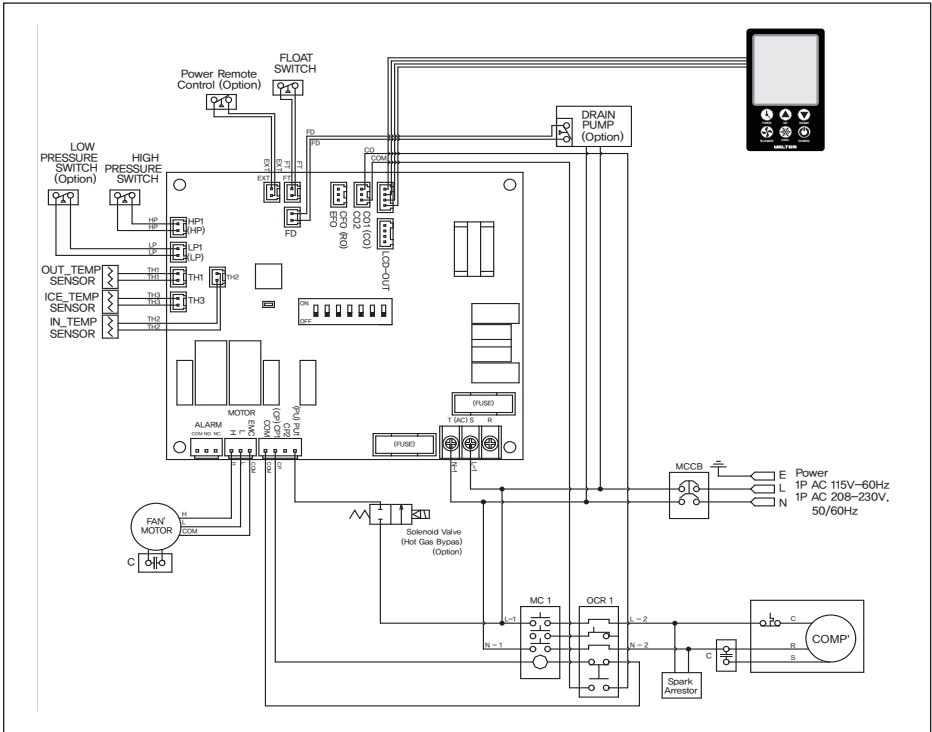

Figure 1 - Circuit Wiring Diagram (7KK14, 7KK21)

Wiring Diagram

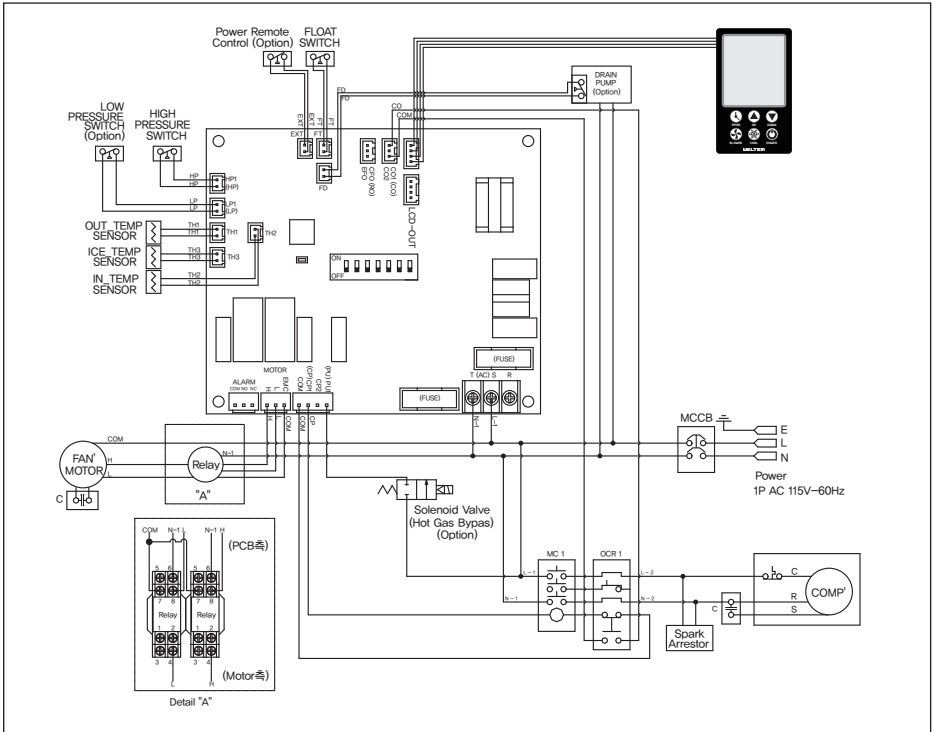

Figure 2 - Circuit Wiring Diagram (7KK17)

General Safety Information

Please read this manual carefully for instructions on correct installation and usage. Please read all safeguards.

1. Transport and store the unit in an upright position only. Leave unit in an upright position for at least 3 hours before first use.
2. Always place the unit on an even, level surface.
3. Ensure the unit is connected to a grounded power supply of the correct rating / capacity.
4. The unit will cool when the room temperature is between 64°F ~ 113°F depending on the thermostat setting.
5. DO NOT use this unit for functions other than those described in this instruction manual.
6. DO NOT tilt the unit.
7. DO NOT cover or obstruct the unit's inlet and outlet grilles.
8. DO NOT use the unit in areas where it will be exposed to rain or water.
9. NEVER unplug the unit while it is operating.

▲ WARNING *DO NOT use the unit in wet environments, such as a laundry room, to avoid the risk of electrical shock.*

10. DO NOT place any foreign objects on the unit.
11. DO NOT operate the unit with wet or damp hands.
12. DO NOT allow chemical substances to come into contact with the unit.
13. DO NOT operate the unit in the presence of flammable substances or vapors such as alcohols, pesticides, gasoline, etc.

▲ WARNING *DO NOT operate the unit in explosive or flammable environments.*

14. DO NOT use the plug to start and to stop the unit. Always use the control panel to start and to stop the unit.
15. Always turn off the unit when it is not in use and unplug the power plug from the electrical outlet.
16. Always turn the unit off and unplug the main power plug from the electrical outlet before cleaning, moving or performing maintenance.
17. AVOID the use of adapter plugs or extension cords. If it is necessary to use an extension cord or an adapter plug to operate the unit, ensure that they are correctly rated for the application. Consult a local qualified electrician and all local electrical codes to ensure proper setup. Any extension cord used with this device must be rated for a minimum of 15A (120V).

18. DO NOT unplug the unit by pulling on the electrical cord. Keep electrical cord away from heat sources and always completely unroll the cord to avoid overheating. If the power cord becomes damaged, contact a qualified repair technician or a qualified electrician to perform replacement or repair of the power cord, plug, or prongs.

▲ WARNING *DO NOT operate a unit with a damaged power cord.*

19. The filters must be used with the product at all times. When the filters are removed for cleaning, always ensure that the unit has been turned off and unplugged from the electrical outlet.
20. Regularly clean the filters to maintain efficiency. If the filters are not cleaned regularly, the units output performance and efficiency will decline and energy consumption will increase.
21. DO NOT operate the unit with a damaged power cord or plug, after it malfunctions, has been dropped or damaged.
22. Only use in the upright position on an even, flat surface. Unit must be positioned at least 24 inches (60 cm) from the nearest object in any direction.
23. Stop operation immediately if abnormal noise or odor is detected. Contact a local service center.
24. Appliance should never be operated by children or unqualified personnel.
25. Children are not to play with appliance.
26. The appliance shall be installed in accordance with national, state, and local wiring regulations.
27. If the supply cord is damaged, it must be replaced by a qualified repair technician or a qualified electrician.
28. This appliance is not intended for use by persons (including children) with reduced physical, sensory or mental capabilities, or lack of experience and knowledge, unless they have been given supervision or instruction concerning use of the appliance by a person responsible for their safety.
Children should be supervised to ensure that they do not play with the appliance
29. If it is necessary to take precautions during installation of the appliance, appropriate details shall be given.
30. The instructions for fixed appliances shall state how the appliance is to be fixed to its support.
The method of fixing stated is not to depend on the use of adhesives since they are not considered to be a reliable fixing means.

31. Instructions and other text required by this standard shall be written in an official language of the country in which the appliance is to be sold.
32. The dimensions of the space necessary for correct installation of the appliance including the minimum permissible distances to adjacent structures
33. A wiring diagram with a clear indication of the connections and wiring to external control devices and supply cord
34. The method of connection of the appliance to the electrical supply and interconnection of separate components
35. Details of type and rating of fuses, or rating of circuit breakers

SAVE THESE INSTRUCTIONS

Unpacking

After unpacking the unit, carefully inspect unit for any damage that may have occurred during transit. Check for any loose, missing, or damaged parts.

Assembly (7KK14, 7KK17, 7KK21)

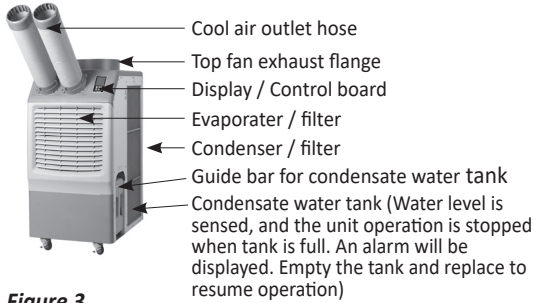

Figure 3
Front and Right side View

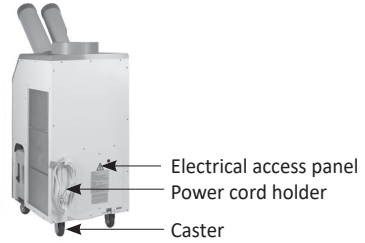

Figure 4
Back and Left side View



POWER CORD HOLDER

1. Take out the cord holder from the accessory box.
2. Place the cord holder on the back side of air conditioner.
3. Use screws (enclosed inside of accessory box with cord holder) to install the cord holder on the air conditioner as shown in Figure 4.

Figure 5



TOP FAN EXHAUST FLANGE

1. Remove the top fan exhaust flange from carton.
2. Place the top fan exhaust flange on the top of air conditioner.
3. Use screws (enclosed inside of box with the top fan exhaust flange) to install the top fan exhaust flange on air conditioner as shown in Figure 6.

Figure 6

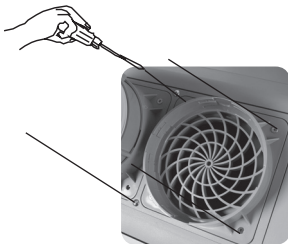

DISCHARGE DUCTS/SUPPLY AIR DUCT

1. Remove cool air outlet hose(s) from carton.
2. Place the cool air outlet hose(s) on the front top of air conditioner.
3. Use screws (enclosed inside of box with cool air outlet hose(s)) to install the cool air outlet hose(s) on the air conditioner as shown in Figure 7.

Figure 7



Figure 8

CONVENIENT DETACHABLE DUCTS

The twist-on ducts are easily added or removed making air conditioner management more convenient.

Installation

WARNINGS REGARDING PROPER LOCATION FOR INSTALLATION

- ▲ WARNING** *Do not use the unit in explosive environments or in areas where flammable gas leakage may occur.*
- ▲ WARNING** *Do not use the unit in areas where it will be exposed to rain or water.*
- ▲ WARNING** *Do not use the unit in a corrosive atmosphere.*
- ▲ WARNING** *Do not use the unit above 64~113°F.*
- ▲ WARNING** *Do not install the unit on uneven or sloping surface. The unit may roll or topple over even if the casters are set to the locked position.*

MOVING THE UNIT

Unlock the casters and push the unit using the side handles to a flat, level surface and set the caster brakes to the locked position.

PLUGGING IN THE UNIT

Check the prongs and surface of the power cord plug for dust/dirt. If dust and/or dirt are present, wipe off with a clean, dry cloth.

Check the power cord, plug and prongs for damage or excess play.

If any damage or excess play is found, contact a qualified repair technician or a qualified electrician to perform replacement or repair of the power cord, plug or prongs.

- ▲ WARNING** *If the power cord or plug is damaged, repair should only be performed by qualified electrical personnel.*
- ▲ WARNING** *Do not connect / disconnect the power cord or attempt to operate buttons with wet hands. This could result in electrical shock.*

NOTE: Make sure the AC outlet is free of dirt, dust, oil, water, or any other foreign material. The unit is equipped with an approved NEMA plug configuration.
(7KK14: 5-15P, 7KK17: 5-20P, 7KK21: 6-15P)
The appropriate outlet must be used for each plug type.

Operation

CONTROL PANEL

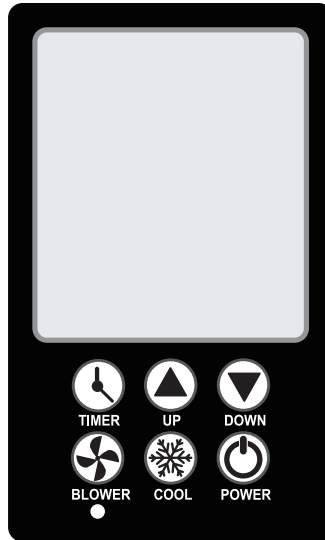
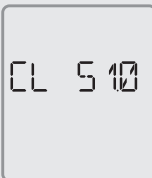

Figure 9



- Press the power button for 2 seconds to activate the product.
- Press the power button for 2 seconds while driving to stop the product.
- Self-diagnosis will be performed to test for abnormalities, after marking “VER” for 3seconds when power is “ON”. And the blowing is operated as “High”, and the compressor is operated after 1 minute.



← Example of “VER” sign when it's ON



COOL

Cooling mode.

1) Cooling mode

- The basic operation is based on “out” control. (discharge temperature TH1)
- On/off the operation of the compressor. (COOL ↔ BLOWER)
- The set temperature cannot be changed and it operates which is set to 0 degrees Celsius.

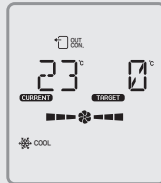

← Example of normal operation of cooling mode.

2) When blower is operating

- LOW → HIGH → AUTO It consists of three modes and operates in circulation.
- LOW, HIGH, AUTO In “LCD”, the middle wing of each mode rotate and operate.

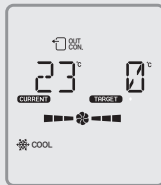



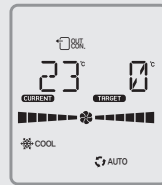



← LOW Examples of moves.



← AUTO Examples of moves.

· AUTO MODE

- If the power source becomes “on” after “off”, it operates as “auto” and then as “high” or “low” depending on the sensor value after 3 seconds.
- The difference between “current temp” and “target temp” operates as “high” when it is 8 degrees Celsius or higher, and “low” when it is 6 degrees Celsius or lower.

 <p>BLOWER UP LOCK MODE</p>	<p>1) It is a mode that prevents the operation of the rest of the buttons except for power.</p> <ul style="list-style-type: none"> · It can be operated and released by pressing for 2 seconds. <div style="display: flex; justify-content: space-around; align-items: center;"> <div style="text-align: center;">  <p>← Example of a set-up.</p> </div> <div style="text-align: center;">  <p>← Example of releasing it.</p> </div> </div>
 <p>BLOWER Blowing mode</p>	<p>1) The compressor does not operate, but only the blowing fan operates.</p> <ul style="list-style-type: none"> · LOW → HIGH → AUTO It consists of three modes and operates in circulation. <div style="text-align: center;">  <p>← Example of blowing.</p> </div>
<p>Reservation mode</p>	<p>1) It's the off reservation mode.</p> <ul style="list-style-type: none"> · Press the 'time' button for 2 seconds, select the 'blower' button, and select 'on/off', minutes as the 'up/down' button. · You can choose to make a reservation for turning it on → ON, off → OFF. · It can be adjusted every 30 minutes with 'up/down' and up to 720 minutes (12 hours). · If the 'time-up' button or the time is "0", the reservation will be canceled. <div style="text-align: center;">  <p>← Example of displaying the remaining time (minutes) during "timer" operation during cooling.</p> </div>

Maintenance

FILTER CLEANING *(See Figures 10 and 11)*

There are two filters in the unit. The evaporator filter is located at the front of the unit. The condenser filter is located at the side of the unit.

1. Loosen up 2 bolts on the front filter guard.
2. Slide filter up and use a vacuum cleaner to remove the dust from the filter.
3. If the filter is heavily covered with dust and dirt, warm water and mild soap or neutral detergent may be used to wash the filter. Do not use any other chemicals to clean filter, as they will likely damage the filter.
4. Dry the filter in a shaded area before replacing it. Do not operate the unit without the filter installed and the filter guard in the closed position.
5. Replace the clean filter and close the filter guard.
6. To clean the condenser filter, lift up on the side filter from the middle bar slightly and then angle the filter outwards from the bottom and remove.
7. Use the same cleaning procedure as above (3 – 5).
8. To replace the condenser filter, place the top of the filter in the guide and slide the filter up until the bottom of the filter clears the frame. Then push the bottom of filter into the guide and let filter gently fall inside the guide.

NOTE: For effective cooling clean the filter at least every 2 weeks.

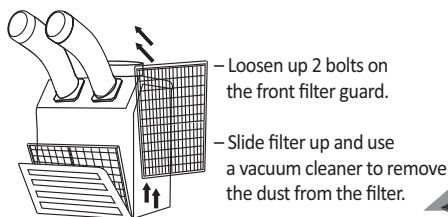

Figure 10 – Removing Filters

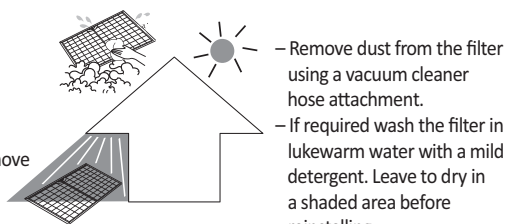

Figure 11 – Removal of Dust

▲ WARNING *Do not operate without the filter fitted.*

▲ WARNING *Do not operate the unit with a damaged cord or plug, after the unit malfunctions, or if the unit has been dropped or damaged.*

Maintenance (Continued)

- For your convenience, record the complete model number and product name (located on the Product Identification Plate), the purchase date, purchase location, serial number, and warranty period in the table below.
- Also, attach your purchase receipt as proof of purchase to this instruction manual for future reference.
- To ensure your product is covered by warranty, the complete faulty product along with your original purchase receipt must be provided at the place of purchase.
- To ensure your product is covered by warranty, the complete faulty product along with your original purchase receipt must be provided at the place of purchase.

Product	Portable Air Conditioner
Model No.	_____
Date of Purchase	_____
Place of Purchase	_____
Serial No.	_____
Period of Warranty	_____

Customer: Please read and keep this manual for future reference and keep sales receipt as proof of purchase.

SPRING REPLACEMENT (See Figure 12)

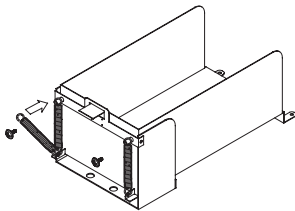

Figure 12 – The process of spring replacement

There are two springs on the rear of condensate water tank guide.

1. Release the screw on the spring hook.
2. Take off the spring hook, and then pull out the opposite spring hook from hole in the condensate water tank guide.
3. Replace with a new spring in reverse order.
4. Repeat this cycle for the other spring.

SELF-DIAGNOSTIC CODES (See Table 1)

If abnormal operation occurs, an alarm light will be activated and a code will be displayed on the control panel. The compressor and condenser fan motor will stop operating. The evaporator fan will continue to run for 3 minutes. If the fault is rectified within 3 minutes, the unit will resume operation. If the fault persists for more than 3 minutes, the evaporator fan also stops. The fault must be rectified before the unit can resume normal operation.





SELF-DIAGNOSTIC ALARM CODES			
Alarm Display	Problem	Cause	Corrective Action
	Compressor overloaded	<ul style="list-style-type: none"> • Ambient temperature is too high • Unstable voltage supply • Defective compressor 	<ul style="list-style-type: none"> • Do not use the air conditioner if ambient temperature is higher than 113°F • Contact a qualified service agent • Replace compressor
	Condensate water level alarm	Condensate tank is full	<ul style="list-style-type: none"> • Empty the water tank • After installation of the now empty water tank, press the SPOT/COOL or ROOM/COOL button to resume operation
	Drain pump alarm	Drain pump defective or improper hose connection (including kink or blockage)	<ul style="list-style-type: none"> • Check the connection and hose • Replace drain pump
	Refrigerant high pressure switch	<ul style="list-style-type: none"> • Blocked air filter • Blocked / kinked exhaust duct • Ambient temperature is too high 	<ul style="list-style-type: none"> • Clean air filter • Ensure exhaust duct is not blocked / kinked • Do not use the air conditioner if ambient temperature is higher than 113°F

Table 1- Alarm Codes





SELF-DIAGNOSTIC ALARM CODES			
Alarm Display	Problem	Cause	Corrective Action
	Abnormal temperature sensor value	TH1(Outlet) temperature sensor has a loose or broken connection	Contact a qualified service agent
	Abnormal temperature sensor value	TH2(Inlet) temperature sensor has a loose or broken connection	Contact a qualified service agent
	Abnormal temperature sensor value	TH3 (Prevention of Freeze) Sensor open circuit or poor connection.	Contact a qualified service agent
	Frost prevention sensor and Abnormal temperature sensor value	<ul style="list-style-type: none"> Indoor heat exchanger temperature too low TH3 temperature sensor has a loose or broken connection 	<ul style="list-style-type: none"> Do not use the air conditioner if ambient temperature is lower than 64°F Contact a qualified service agent

Table 1- Alarm Codes

Troubleshooting chart

Symptom	Possible Cause(s)	Corrective Action
Water leakage	High water level in condensate tank	<ol style="list-style-type: none"> 1. Remove blockage from drain hose 2. Remove any object stuck underneath the black panel underneath the water tank
The unit doesn't work	<ol style="list-style-type: none"> 1. Check the power supply to verify that power is available to the unit 2. Verify that the power cord is connected 	<ol style="list-style-type: none"> 1. Reset the circuit breaker and restart the unit 2. Connect power cord
No cold air flows from the cold air outlet	<ol style="list-style-type: none"> 1. Ambient air cannot be properly cooled if the filter is dirty and not regularly cleaned 2. Compressor will not work if the unit is turned off and on quickly. 3. The ambient air temperature may be too high 	<ol style="list-style-type: none"> 1. Clean the filter 2. Wait 2 minutes after unit is turned off before turning the unit back on. 3. The temperature of the compressor can be higher when the ambient temperature is too high. The compressor will not work unless the ambient air temperature is within the acceptable operating range of the unit
Water flow can be heard after compressor shuts off	No cause	Common to hear coolant flowing after unit shuts off
Alarm displays "FT" with less than half of condensate water in the tank Spring is possibly broken	Spring is possibly broken	Replace a new spring (See Maintenance page 13)

SHIPPING LIST

- (1) Portable Air Conditioner
- (1) Owner's Manual
- (1) Power Cord Holder
- (2) Discharge / Supply Air Ducts
- (1) Exhaust Flange

OBTAINING SERVICE

If the Koldwave Portable Air Conditioner requires Service:

1. Use the TROUBLESHOOTING section in this manual to eliminate obvious causes.
2. Verify there are no circuit breakers tripped.
3. Call your dealer for assistance. If you cannot reach your dealer, or if they cannot resolve the problem, call Koldwave Portable Air Conditioner Technical Support at 413-564-5520. Please have the following information available BEFORE calling the Technical Support Department:
 - a. Your name and address.
 - b. The serial number of the unit.
 - c. Where and when the unit was purchased.
 - d. All of the model information about your Koldwave Portable Air Conditioner.
 - e. Any information on the failure, including LED's that may or may not be illuminated.
 - f. A description of the protected equipment, including model numbers if possible.

LIMITED PRODUCT WARRANTY

Koldwave warrants all Koldwave products to be free from defects in materials or workmanship, under normal use and service, for a period of twelve (24) months from date of shipment from the factory. Koldwave further warrants that the refrigeration compressor will be free from defects in materials and workmanship for (3) years from date of shipment from the factory.

Koldwave's obligation under this warranty is limited to the repair or replacement at its option, of any part or parts which, upon Koldwave's examination at its factory, are shown to be defective or at Koldwave's option, the return of the purchase price to the purchaser. Correction of such defects by repair or replacement, or, at Koldwave's option, the return of the purchase price shall constitute fulfillment of warranty obligations to the purchaser.

This warranty does not cover corrosion or normal deterioration, or any transportation or labor charges paid for replacement of parts, adjustments, repairs or any other work. All replacement parts shall be shipped F.O.B. from Koldwave, Farmville, North Carolina, and all parts returned to Koldwave's factory shall be at buyer's expense.

Replacement of all parts hereunder shall not operate to extend the original warranty period as to any part, including replacement parts supplied hereunder.

THE ABOVE WARRANTY HERewith SET FORTH IS IN LIEU OF AND SUPERCEDES ALL OTHER WARRANTIES INCLUDING IMPLIED WARRANTIES OF MERCHANTABILITY AND/OR FITNESS FOR A PARTICULAR PURPOSE.

Koldwave shall not be liable for any loss, damage, cost of repair or incidental or consequential damages of any kind in connection with the sale, use or repair of any Koldwave products. Any repairs made outside of Koldwave's factory without its written consent will void this limited warranty. This limited warranty shall be void if the equipment has been subjected to misuse, negligence, free chemicals in the system, improper maintenance or is operated contrary to the manufacturer's recommendations, or if the serial number has been altered, defaced or removed. Buyer assumes all liability for damages resulting from such handling, possession or use of the product. No representative of Koldwave or its distributors or dealers is authorized to assume for us any obligation or liability in connection with this product, nor to alter the terms of this warranty in any way.

LIABILITY UNDER THIS WARRANTY SHALL NOT ATTACH AND BECOME EFFECTIVE UNTIL KOLDWAVE HAS BEEN PAID IN FULL FOR PRODUCT SUPPLIED.

For Koldwave warranty please visit
<http://koldwave.com/html/literature.asp>

KOLDWAVE
260 North Elm St.
Westfield, Ma 01085, USA
PH: 413-564-5530 Fax: 252-753-1953
www.koldwave.com

1D M Koldwave2303140301
