

AVALON

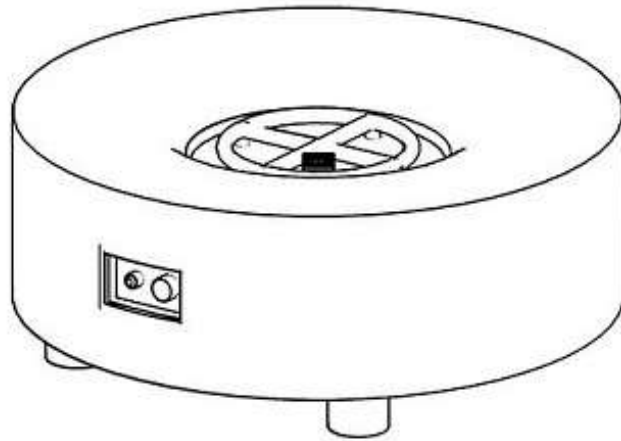

BODY SPECIFICATIONS

Material: Fiberglass reinforced concrete
Available colors: Slate grey, Charcoal grey

BURNER SPECIFICATIONS

Certification: CSA listed
Heat Output: 60,000 BTU
Material: 304 stainless steel
Fuel Type: Natural gas, propane
Ignition: 12v DC battery (electronic)

WEIGHT

200 pounds with media

OPTIONAL ACCESSORIES

Burner cover SKU: ABC-30R
Wind guard SKU: GWS-30R
NG conversion kit SKU: CON-NG
LP conversion kit SKU: CON-LP

WARRANTY

Limited 2 year

